

LAGAN

CN

GB



Design and Quality
IKEA of Sweden



请参见

www.IKEA.com

选择当地商店，查看其联系电话和营业时间。



Please refer to
www.IKEA.com
and select your local store for local store phone numbers and opening times.

中文	5
ENGLISH	19

目录

安全信息	5	保养与清洁	12
安全说明	7	故障排除	12
安装	8	技术规格	14
产品描述	9	环保清单	15
操作	10	环保要求	15
首次使用	10	宜家质保	17
提示与建议	11		

如有变更，恕不另行通知。

▲ 安全信息

安装和使用本设备前，请仔细阅读产品说明书。因安装不正确和使用错误所导致的人身伤害和设备损坏，制造商概不负责。始终将本说明书与设备一同妥善保存，以备将来参阅。

儿童和弱势群体安全指南

- 器具不打算由存在肢体、感官或精神能力缺陷或缺少使用经验和知识的人（包括儿童）使用，除非有负责他们安全的人对他们进行与器具使用有关的监督或指导。
- 应照看好儿童，确保他们不玩耍本器具。
- 请将所有的包装放在远离儿童的地方，并妥善地处理它们。

一般安全指南

- 本电器适用于家庭及以下类似场景：
 - 农舍；商店、办公室及其他办公场所的用餐区域；
 - 酒店、汽车旅馆、简易旅馆等住宿业的客户；
 - 餐饮和非零售行业应用场景。

- 该冰箱广泛应用于宾馆、办公室、学生宿舍和住宅等场所。主要适用于水果、饮料等食品的冷藏保鲜。该产品尺寸小巧，重量较轻，耗电省，而且便于使用。
- 警告:器具周围或在嵌入式结构里无阻碍物,保持通风通畅。
- 警告:除了制造商推荐的方式外,不得使用机械设备或其他方式加速除霜过程。
- 警告:不得损坏制冷回路。
- 警告:除了制造商推荐使用的类型外,不得在器具的食品储藏室使用电器。
- 请勿使用喷水和蒸汽来清洁设备。
- 请使用微湿的软布来擦拭设备。只能使用中性洗涤剂。请勿使用研磨器具、研磨清洗垫、溶剂或金属物体清洗。
- 不得在器具中贮存爆炸物,如助燃喷雾剂。
- 如果电源软线损坏,为了避免危险,必须由制造商、其维修部或类似部门的专业人员更换。
- 安放设备时,请确保电源线没有卡住或损坏。
- 请勿将多用便携式插座或便携式电源置于设备背后。
- 多次长时间开启门会导致隔间温度明显升高。
- 定期清洁可能接触到食物和靠近排水系统的表面。
- 如果水箱已 48 小时未使用,则应清洁后再启用;如果连续 5 天没有取水,则应冲洗与供水系统相连的管件。
- 生肉和鱼应装在适当容器内再放入冰箱,以免接触或滴到其他食物上。
- 如果冰箱长期空置,应关闭电源,除霜,清洁,干燥,并保持冰箱门开着,以防内部产生霉菌。
- 二星冷冻食品室适合储存预冻食品、储存或制作冰激凌以及制作冰块。
- 一星、二星和三星隔室不适合冷冻新鲜食品。
- 该冰箱不适用于储存冷冻食品。
- 该冰箱不能用作嵌入式安装。
- 该设备配有内部照明灯。只有售后服务人员可以更换照明装置。联系授权服务中心。
- 警告:为了避免由于器具固定不稳导致的危险,应根据说明书的要求来安装固定。

安全说明

安装

警告！ 本设备必须由具备资质的人员进行安装。

- 安装前需拆下所有包装和运输螺栓。
- 请勿安装或使用已损坏的设备。
- 请按照随附的安装指引来安装设备。
- 设备较重，请小心移动。始终使用安全手套和封闭式鞋子。
- 请确保设备周围的空气正常流通。
- 搬动设备过程中，设备与垂直方向的倾角不得大于 45°。
- 将设备连接电源前至少要放置 4 小时。此举是为了等待机油回流至压缩机中。
- 请勿将设备安装在靠近暖气、炊具、炉子或灶台的地方。
- 设备背面必须靠墙放置。
- 请勿将设备安装在阳光直射的地方。
- 请勿将设备安装在过于潮湿或阴冷的地方，例如地下室、车库或酒窖。
- 当您移动设备时，请从前缘抬起设备，以免划伤地板。

电气连接

警告！ 火灾和触电风险。

警告！ 安放设备时，请确保电源线没有卡住或损坏。

警告！ 请勿使用接线板和电源延长线。

- 设备必须接地。
- 确保铭牌上的电气参数与主电源的电气参数相匹配。
- 始终用正确安装的防电击插座。
- 请确保不会损坏电气部件（例如电源插头、电源线、压缩机）。请参见

www.IKEA.com

联系本地商店以获取其联系电话和营业时间，也可请电工更换电气部件。

- 电源线位置必须低于电源插头。
- 须在安装完成后，再将电源插头连接至主电源插座。在安装完成后，请确保仍能接触到电源插头。
- 切断设备的电源时，请勿拉拽电源线。始终通过拔下电源插头来断电。

使用

警告！ 人身伤害、烧伤、触电或火灾风险。



警告！ 火灾危险/可燃材料

本设备含有易燃气体，异丁烷（R600a），一种具有高度环境兼容性的天然气。注意不要损坏含异丁烷的制冷剂回路。

- 压缩机表面发烫：压缩机在正常工作时表面可能发烫。请勿用手触摸。
- 请勿更改本设备的规格。
- 除制造商声明可使用的型号外，请勿将电气设备（如冰激凌机）放置于冰箱中。
- 如果制冷剂回路损坏，请确保室内无明火和火源。请对室内进行通风。
- 请勿让高温物体接触设备的塑料部件。
- 请勿将软饮料放入冷冻食品室。这会在饮料容器上形成压力。
- 请勿在冰箱内存放可燃气体和液体。
- 请勿将易燃产品或沾有易燃液体的物品放在设备内部、附近或上方。
- 请勿触摸压缩机或冷凝器。它们是发热部件。
- 请勿用湿手触碰或取出冷冻食品室内的物品。
- 请勿将解冻后的食物放回冷冻食品室。
- 请遵循冷冻食品包装上的储存说明。

内置灯

警告！ 触电风险。

- 内置灯仅可用于设备内部照明。请勿将其用于室内照明。

保养与清洁

警告！ 磨损和损坏设备的风险。

- 在进行维护前，请关闭设备并将电源插头从插座上拔下。
- 冷却装置内含有碳氢化合物。须由具备资质的人员维护和填充冷却装置。
- 请定期检查设备的排水口；必要时，请对它进行清理。如果排水口被堵塞，解冻的水会聚集在设备的底部。

联系我们的售后客服

- 您在拨打服务电话时，宜家售后客服中心会在电话中协助您解决设备的基本问题。请参见

www.IKEA.com

选择当地商店，查看其联系电话和营业时间。

废弃处理

警告！人身伤害或窒息风险。

- 将设备与主电源断开。
- 将电源线切断并丢弃。
- 卸下冰箱门，以防儿童和宠物被关在设备内。
- 本设备的制冷剂回路和绝缘材料对臭氧无害。
- 绝缘泡沫含有可燃气体。请您与所在的市政当局联系，以了解如何正确丢弃此设备。
- 请勿损坏靠近热交换器的冷却装置部分。

安装

警告！请参考“安全”章节。

选位

- 安装此设备时，请参照独立的《组装说明》。
- 请勿将其安装在高温潮湿的地方。避免损坏、受潮和生锈。
- 设备应安装在干燥、通风良好的室内区域，且环境温度符合设备铭牌上标明的气候等级：

气候等级	环境温度
亚温带型 (SN)	+10°C 到 +32°C
温带型 (N)	+16°C 到 +32°C
亚热带型 (ST)	+16°C 到 +38°C
热带型 (T)	+16°C 到 +43°C

- “SN”表示该冰箱适宜在 10°C 至 32°C 的环境温度下使用。
- “N”表示该冰箱适宜在 16°C 至 32°C 的环境温度下使用。
- “ST”表示该冰箱适宜在 16°C 至 38°C 的环境温度下使用。
- “T”表示该冰箱适宜在 16°C 至 43°C 的环境温度下使用。

警告！如果器具在额定气候类型（环境温度范围）以外运行，则器具可能不能维持满意的室内温度。

某些型号在运行范围外运作时会出现功能问题。只有在规定温度范围内才能保证正常运行。

如您对设备安装有任何疑问，请向零售商、我们的客服中心或就近的授权服务中心咨询。

安装位置

- 为确保最佳运行性能，请将设备安装在远离热源（如散热器、锅炉、阳光直射等）的地方。确保空气在机柜背面流通顺畅。

警告！为确保在 38°C 以上的环境温度下正常运行，建议使设备两侧与周围家具之间保持 30mm 的距离。

电气连接

警告！请勿移除接地线。请勿使用电源适配器。请勿使用电源延长线。未遵守上述说明可能导致死亡、火灾或触电。

在通电之前，请确保铭牌上显示的电压和频率与您的家用电源相符。

设备必须接地。电源线插头配有接地触点。如果家用电源插座未接地，请咨询电气技师，将设备与符合电流要求的独立接地点连接。

如果用户未遵守以上安全措施，制造商概不负责。

产品描述

使用设备前请仔细阅读操作说明。

- 1 玻璃搁架
- 2 三星冷冻食品室
- 3 温度调节器和内部照明
- 4 可变存储盒
- 5 果菜盒
- 6 铭牌

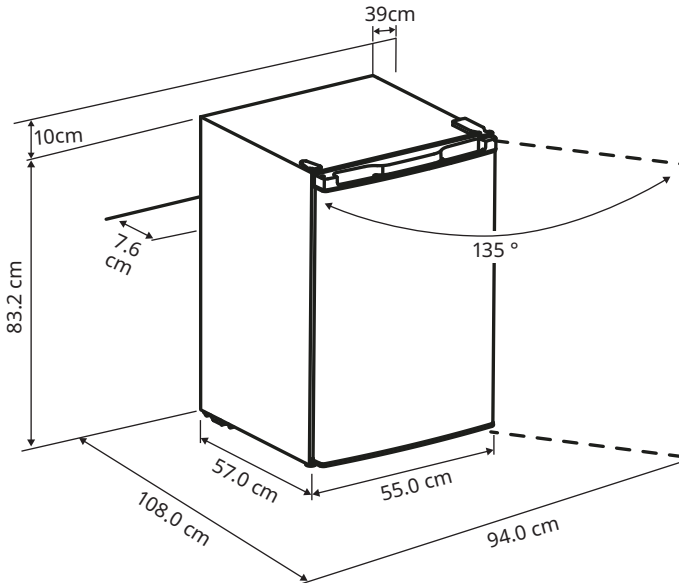
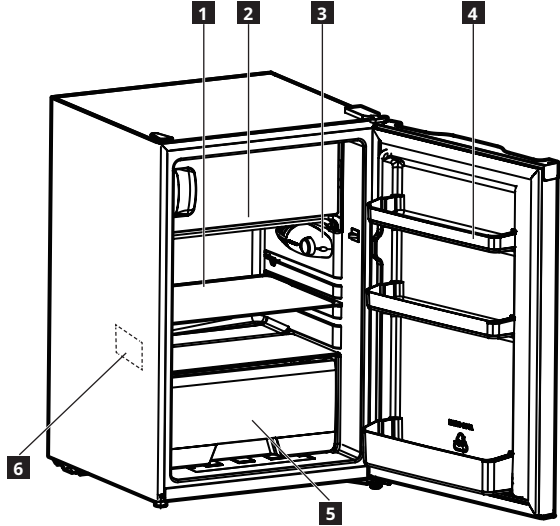

操作

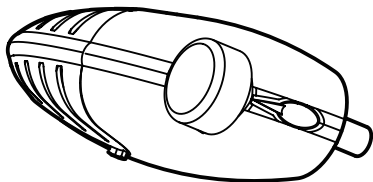

启动

将电源插头连接到电源插座。将温度调节器设置为中等值(参考“温度调节”)。

第一次运行冰箱时，将其温度调低，不放食物空载运行，直到它稳定在设定的温度。这个过程通常需要 2 到 3 小时，然后将温度调节器调到所需温度，放入食物。

关闭

将温度调节器调至“关闭”位置，即可关闭设备。

在放入食物前，需给设备足够时间完全冷却。最好等 24 小时后再放入食物

温度调节

温度可自动调节。

请按照以下方式操作设备：

- 将温度调节器调至较低制冷设置，可获得最低制冷效果。
- 将温度调节器调至较高制冷设置，可获得最高制冷效果。

i 通常最适合使用中间设定值。

调整温度设置时，需谨记设备内部温度取决于：

- 室温
- 冰箱门开关的频繁程度
- 食物存储量
- 设备位置

重要提示！ 在环境温度较高或冰箱内塞满食物的情况下，如果设定的是最低温度，冰箱连续运行会导致后壁结霜。因此，环境温度较高时，冰箱要设置自动除霜，从而减少能耗。

首次使用

清洗设备内部

首次使用设备前，请用温水和中性皂液清洗内部和所有内部附件以去除常见的新设备异味，然后彻底干燥。

重要提示！ 请勿使用洗涤剂或研磨粉，因为这些会损坏设备表面。

提示与建议

正常运行声音

运行过程中发出下列声音是正常的：

- 当泵送制冷剂时，线圈会发出轻微的流水声和水泡声。
- 当泵送制冷剂时，压缩机会发出呼呼声和跳动声。
- 因热膨胀效应，设备内部会发出咯咯声响（不存在危险性的自然物理现象）。

节能提示

- 请勿频繁开关冰箱门或让冰箱门长时间处于打开状态。
- 如环境温度高，内部温度设置过低，且设备满载，则压缩机可能会持续运行，导致蒸发器结霜或结冰。如发生这种情况，应将内部温度适当调高，让设备自动除霜，从而节省耗电。

新鲜食品冷藏提示

- 请勿在冰箱中储存热食或易挥发液体。
- 请覆盖或包裹好食物，特别是当食物有强烈的味道时。
- 合理放置食物，保持周围空气流通。

冷藏提示

实用建议：

- 肉类（所有类型）：须适当包裹后再放在蔬菜抽屉上方的玻璃架上。肉类最多储存 1-2 天。
- 熟食、凉菜：须盖好容器后再放在任意架子上。
- 水果和蔬菜：彻底清洗后放置在专用抽屉内。请勿将未包装的香蕉、土豆、洋葱和大蒜放入冷藏室。
- 黄油和奶酪：放在特制密封容器中，或用铝箔纸或塑料袋包裹，尽可能排净空气。
- 瓶子：盖好盖子，放在门旁瓶架上，或专用瓶架上（如果有的话）。

使用时的注意事项

- 冰箱中放置的食物越多或者开门次数越多、持续时间越长，耗电量就越大，甚至会造成机械故障。
- 间隔十分钟左右重接电源。
- 请勿将瓶装饮料放入冷冻食品室，以防瓶子破碎并损坏冰箱。
- 断电后尽量减少冰箱门的开关次数。
- 除霜时，请勿使用尖锐或金属物体清除蒸发器表面的冰霜，以免损坏蒸发器。
- 请勿用湿手触摸冷冻食品室内的食物和容器，以防冻伤。

储存冷冻食品

- 如果是首次使用或长时间不用，那么在放入食品之前，要让设备在低温设置下运行至少两个小时。
- 当你密封包装时，不可让空气或水分进出。如果密封不严，冰箱里的食物就会串味和流失水分。
- **注意：**请勿将瓶装食物或饮料放入冷冻食品室。
- 为了达到最佳性能，请在冷冻食品室中留出足够空间，让食物周围的空气流通。冰箱前部留出足够的空间，以便门能完全关闭。

冷冻食物储存提示

要使设备发挥最佳性能，您应该：

- 确保购买零售商正确储存的商品。
- 确保尽快将冷冻食品从食品储存盒转移到冷冻食品室中。
- 请勿频繁开关冰箱门或让冰箱门长时间处于打开状态。
- 一旦解冻，食物很快就会变质，不能重新冷冻。
- 储存时，请勿超出食品制造商规定的储存期限。



警告！ 如果因停电等原因导致意外解冻，且断电时间超过了技术特性表中的“上升时间”，则解冻的食物必须迅速食用。

解冻

取决于可用的时间，深度冷冻或冰冻的食物在使用前，可以在冷藏室或室温下解冻。

建议：所冷冻的食品不能直接与室内已储藏的食品接触，并且，如果需要每天都要冻结食品时应减少冷冻食品的数量。

小块的食物甚至可以从冷冻食品室取出后直接烹调：在这种情况下，烹调的时间会更长。

保养与清洁

⚠ 警告！ 请参考“安全”章节。

常规警告

⚠ 警示！ 在进行任何冰箱保养工作前请拔出插头。

ⓘ 设备的冷却装置内含有碳氢化合物；因此，必须由具备资质的技术人员维护和填充冷却装置。

ⓘ 请勿使用洗碗机清洗设备的附件和部件。

清洗设备内部

首次使用设备前，请用温水和中性皂液清洗内部和所有内部附件以去除常见的新设备异味，然后彻底干燥。

⚠ 警示！ 请勿使用洗涤剂或研磨粉，因为这些会损坏设备表面。

冰箱/冰柜外部清洁

使用蘸有温水和中性肥皂或设备专用清洁剂的软布，对冰箱/冰柜门外部进行清洁。

首次通电

⚠ 警示！ 初次将插头插入电源插座并启动机柜之前，应将设备竖直放置至少 4 小时。确保机油有足够时间回流至压缩机。否则，压缩机或电气部件可能受损。

定期清理

⚠ 警示！ 请勿拉动、移动或损坏机柜内的任何管道和/或电缆。

⚠ 警示！ 请勿损坏冷却系统。

⚠ 警示！ 搬动设备时应从前端边缘搬起，以免划伤地板。

须定期清洗设备：

1. 使用温水和中性皂剂清洗内部和附件。
2. 定期检查并擦拭门上的密封条，以确保密封条清洁无碎屑。
3. 冲洗并彻底干燥。
4. 如果方便的话，可使用刷子清洗设备后部的冷凝器和压缩机。这样可提高设备性能并可节电。

非运行时期

设备长时间不使用时，应采取以下防护措施：

1. 断开设备电源。
2. 移除所有食品。
3. 除霜（如有必要），清洁冰箱及其所有附件。
4. 清洁冰箱及其所有附件。
5. 保持冰箱门开着，以防霉味。

⚠ 警示！ 如要保持设备运行状态，请定期检查，以防停电导致食物变质。

冷藏室除霜

除霜过程是自动的：冷藏室内部背面上的霜融化后，流入外部的滴水盘并自动蒸发。

冷冻食品室除霜

由于季节变化，冷冻室内可能会形成一层厚厚的霜。手动除霜时，请注意以下事项：

- 将恒温器旋钮旋至“关闭”位置，并打开冷冻食品室的门。
- 移除所有食物，将冰块托盘和层架转移到冷藏室。
- 用抹布将融化的霜擦干净。
- 除霜后，将恒温器旋钮归位。
- 在人工化霜、维护或清洁时，所冻结食品的升温可能会缩短储存期。

⚠ 警示！ 为避免破坏冷冻食品室内壁，请勿使用任何尖锐的物体来除霜或分离冷冻食品。

故障排除

⚠ 警告！ 请参考“安全”章节。

常见问题处理

问题	可能的原因	解决方法
设备无法运行。	设备关闭。	打开设备。
	电源插头没有正确连接到电源插座。	将插头正确连接到电源插座。
	设备显示无电。电源插座中无电压。	将不同电气设备连接到电源插座。联系有资质的电气技师。

问题	可能的原因	解决方法
设备有噪声。	设备无恰当支撑。	检查设备运行是否稳定。
照明灯不亮。	照明灯有缺陷。	请联系离您最近的宜家商店。
压缩机持续运行。	温度设定不正确。	参考“操作”章节。
	同时放入很多食品。	等待数小时后再检查温度。
	室温过高。	参考铭牌上的气候等级表。
	设备内存放的食物过热。	将食物冷却至室温后再储存。
	冰箱门没有关好。	参考“关闭冰箱门”章节。
设备内的温度过低或过高。	温度设置不正确。	设定更高或更低的温度。
	冰箱门没有关好。	参考“关闭冰箱门”章节。
	食物过热	将食物冷却至室温后再储存。
	同时放入很多食物。	同时放入较少食物。
	冰霜厚度大于 4-5 毫米。	为设备除霜。
	冰箱门频繁开关。	只在必要时开关冰箱门。
	设备内无冷气循环。	确保设备内有冷气循环。
冷藏室中的食物出现结冰现象。	恒温器旋钮档位调得过高。	将恒温器旋钮旋至较低档位（较高温度）。
	储存的食物接触到了冰箱后壁的制冷剂。	将食物远离冰箱后壁放置。
冷藏室中的食物不凉。	隔间内的通风口堵塞。这不利于冷空气流动。	确保隔间内的空气可以流通。
	开门过于频繁或门未正确关闭。	避免频繁开关冰箱门。
	冰箱或冷藏室中刚刚放入大量食物。	每次放入少量的食物。
	恒温器旋钮档位调得过低。	将恒温器旋钮旋至较高档位（较低温度）。
霜融化后发生泄漏，流到隔间内或地板上。	排水口入口堵塞。	使用清洁喷嘴清除堵塞物。
水分在冰箱内部积聚。	冰箱内的通风口堵塞。	确保隔间内的空气可以流通。
	冰箱门频繁开关。	避免频繁开关冰箱门。
	食物未正确包装。	确保食物正确包装。
	冰箱温度未根据周围环境正确设置。	将恒温器旋钮旋至较高档位（较低温度）。
冰箱门关不上。	层架错位。	确保层架在正确位置。
	门上的密封垫片脏了。	清洁门上的密封垫片。
	设备无法放平。	确保将设备水平安装。

i 如果进行以上检查后您的设备仍然无法正常工作，请就近联系宜家门店。

关闭冰箱门

1. 清洁门上的密封垫片。
2. 如有必要，可调整冰箱门。请参阅单独的《组装说明》。
3. 如有必要，可更换有问题的密封垫片。联系售后服务

更换照明灯

该设备配有内部照明灯。

只有售后服务人员可以更换照明装置。

请联系宜家，登陆

www.IKEA.com

选择当地商店，查看其联系电话和营业时间。

技术规格

产品类别	
产品类型	冷藏柜
安装类型	驻立式
产品尺寸	
高度	832 mm
宽度	550 mm
深度	570 mm
净容积	
冷藏室	97 L
三星冷冻食品室	16 L
除霜系统	
冷藏室	手动
冷冻食品室	手动
能耗	0.51 千瓦时/24小时
能效等级	3 级 (GB 12021.2-2015)
电源电压	220 V~
电源频率	50 Hz
年耗电量	186 kW·h/a
冷藏室冷却能力	4 kg/12h
冷冻室冷冻能力	1 kg/12h
噪声	39 dB(A)

i 产品编号和序列号位于设备内部左侧的铭牌上。

产品编号
(8 位代码) *

序列号
(以 SN 开头的
22 位代码) **

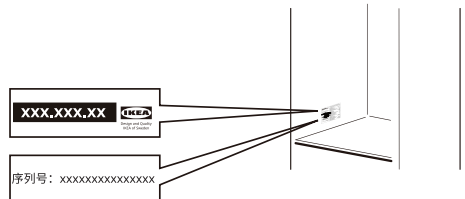

图片仅供参考

产品中的有害物质

产品中有害物质的名称及含有的信息表											
部件名称	有害物质										
	铅 (Pb)	汞 (Hg)	镉 (Cd)	六价铬 (Cr (VI))	多溴联苯 (PBBS)	多溴二苯醚 (PBDEs)	邻苯二甲酸二正丁酯 (DBP)	邻苯二甲酸二异丁酯 (DIBP)	邻苯二甲酸丁苄酯 (BBP)	邻苯二甲酸二(2-乙基)己酯 (DEHP)	
箱体及其组件	○	○	○	○	○	○	○	○	○	○	○
门体及其组件	○	○	○	○	○	○	○	○	○	○	○
压缩机组件及配件	✕	○	○	○	○	○	○	○	○	○	○
PCB 板	✕	○	○	○	○	○	○	○	○	○	○
制冷管路件	○	○	○	○	○	○	○	○	○	○	○
制冷剂	○	○	○	○	○	○	○	○	○	○	○
电器元器件	✕	○	○	○	○	○	○	○	○	○	○
包装印刷组件	○	○	○	○	○	○	○	○	○	○	○
辅料	○	○	○	○	○	○	○	○	○	○	○

注 1:
 ○: 表示该有害物质在该部件所有均质材料中的含量均不超出电器电子产品有害物质限制使用国家标准要求。
 ✕: 表示该有害物质至少在该部件的某一均质材料中的含量超出电器电子产品有害物质限制使用国家标准要求。

注 2: 以上未列出的部件, 表明其有害物质含量均不超出电器电子产品有害物质限制使用国家标准要求。

环保要求

请回收带有 ♻️ 标志的材料。
 请将包装材料放入相应的回收容器中。请回收废旧的电气电子设备, 保护环境和人类健康。请勿将本产品与普通生活垃圾一同丢弃。请将产品送往当地回收机构, 或联系市政部门获取处理指引。



食品接触清单

 提示

- 食品接触清单中零部件包含不同产品型号的部件，具体以实物为准。

冰箱食品接触材料列表

部件名称	部件材质	执行标准	部件名称	部件材质	执行标准
内胆	PS	GB4806.1 GB4806.7	温控盒、旋钮、灯罩	ABS、PS、PMMA	GB4806.1 GB4806.7 GB4806.14
抽屉、果菜盒、 瓶框、储物盒	PS、PP	GB4806.1 GB4806.7 GB4806.14	支撑、接水盘、挂钩、 塑料栏杆、螺钉盖	PP、ABS、PS	GB4806.1 GB4806.7
玻璃搁架组件	玻璃、PS、ABS、PP	GB4806.1 GB4806.7 GB4806.5 GB4806.14	浸塑搁架	碳素结构钢Q195/PE	GB4806.1 GB4806.7 GB4806.9
风道组件	PS	GB4806.1 GB4806.7	吹胀蒸发器	铝1060/聚酯树脂	GB4806.1 GB4806.13 GB4806.7 GB4806.9
小门总成、内门封	PS、TPE	GB4806.1 GB4806.7	标贴	OPP、PET	GB4806.1 GB4806.7

备注：明细表中的部件为不同型号产品所包含的主要部件汇总，部分材质包含但不限于本表列出的材质，本产品是否包含该部件，以产品的实际配置为准。

宜家质保

宜家产品的质保期有多长？

自原始购买之日起，宜家电器享有**五 (5) 年**质保服务。需提供原始销售收据作为购买凭证。如果质保期内出现售后服务，售后服务不会延长产品的质保期限。

哪些 LAGAN 电器不享受宜家的 5 年质保？

对于 2026 年 5 月 1 日之前从宜家购买的 LAGAN 电器，自原始购买之日起，质保期为两 (2) 年。

由谁提供售后服务？

宜家服务提供商将通过其自身的服务运营或由其授权的服务合作伙伴提供服务。

产品质保涵盖哪些内容？

质保涵盖从宜家购买日期算起，由制造问题或不材料导致及设备故障。本质质保仅对家用生效。例外情况已在标题“产品质保不涵盖哪些内容？”下具体说明。质保期内的维修成本，例如修理、配件、人工和差旅费无需用户承担，前提是维修设备时不产生特别支出。在此条件下，适用于各地地方性法规。更换下来的部件将归宜家所有。

宜家将如何纠正问题？

宜家指定的服务提供商将对产品进行检查，并自行决定产品是否在质保范围内。若被视为在质保范围内，宜家服务提供商或其授权的服务合作伙伴将通过其自身的服务运营，自行决定维修有缺陷的产品或将其更换为相同或同等的产品。

产品质保不涵盖哪些内容？

- 正常磨损。
- 故意或疏忽造成的损坏；不遵守操作说明、不正确安装或连接错误电压造成的损坏；化学或电化学反应、生锈、腐蚀或水渍造成的损坏，包括但不限于由供水中的过量石灰造成的损坏；异常环境条件造成的损坏。
- 耗材包括电池和灯。
- 不影响设备正常使用的非功能性和装饰性部件，包括各种划痕和色差。
- 外物以及清洗或疏通过滤器、排水系统或肥皂盒导致的意外损坏。
- 以下部件的损坏：陶瓷玻璃、附件、餐具篮、进水和排水管、密封件、灯和灯盖、屏幕、旋钮、外壳和外壳部件。除非这些损坏能被证明是由生产故障造成的。
- 在技术人员检查期间未发现故障的情况。
- 维修工作不是由我们的指定服务提供商和 / 或授权服务合作伙伴执行，或未使用原厂配件。
- 因错误安装或未按照规范安装而导致的维修。
- 在非家庭环境中使用该设备，即用于专业用途。

- 运输过程中损坏。如果客户将产品运送到自己家或另一地址，宜家对运输中产生的任何损坏概不负责。但是，如果宜家将产品运送到客户指定的送货地址，那么运输途中发生的产品损坏由宜家承担。
- 宜家设备的初装费用。
- 但是，如果宜家指定的服务提供商或其授权服务合作伙伴依照本质保条款维修或更换设备，如有必要，指定的服务提供商或其授权服务合作伙伴将重新安装修复后的设备或安装替换设备。
- 宜家不承担水管和电气安装，客户须在安装设备之前完成此工作。

国家 / 地区法律会如何适用

宜家保修条款赋予您明确的法律权力，涵盖或超出了当地所有的法定要求。然而，这些条件并不以任何方式限制当地法律所规定的消费者权利。

有效区域

本保修条款仅在购买产品的国家/地区有效；服务将在质保条件的框架内提供。只有在设备符合并按照以下规定安装的情况下，宜家才有义务在此质保框架内提供维修服务：

- 提出保修申请时所在国家的技术规格
- 《组装说明》和《用户手册》中的《安全信息》

宜家电器的专用售后服务

请随时联系宜家指定的授权服务中心以便：

- 依据本质保条款提出服务请求
- 咨询如何在宜家专用厨房家具中安装宜家电器
- 就宜家电器的功能进行咨询

为确保我们为您提供最佳协助，请在联系我们之前仔细阅读《组装说明》和/或《用户手册》。

联系我们的售后客服



联系电话：
400-800-2345
营业时间：
星期一 - 星期日
09:00 - 21:00

您在拨打服务电话时，宜家售后客服中心会在电话中协助您解决设备的基本问题。

请参见

www.IKEA.com

选择当地商店，查看其联系电话和营业时间。

在致电我们之前，请确保您能提供需要售后服务的设备的宜家产品编号（8位代码）和序列号（8位代码，可在铭牌上找到）。

- i 请保留销售收据！** 收据是您的购买凭证，也是获得质保的必要条件。请注意，收据还会注明您所购买的每件电器的宜家产品名称和编号（8位代码）。

你需要额外的帮助吗？

如有任何与电器售后无关的其他问题，请联系离您最近的宜家商场呼叫中心。建议您在联系我们之前仔细阅读说明书。

Contents

Safety information	19	Care and cleaning	27
Safety instructions	22	Troubleshooting	28
Installation	23	Technical information	30
Product description	24	Environmental impact list	31
Operation	25	Environmental requirements	31
First use	25	IKEA guarantee	33
Hints and tips	26		

Subject to change without notice.

Safety information

Before the installation and use of the appliance, carefully read the supplied instructions. The manufacturer is not responsible if an incorrect installation and use causes injuries and damages. Always keep the instructions with the appliance for future reference.

Children and vulnerable people safety

- This appliance is not intended for use by persons (including children) with reduced physical, sensory or mental capabilities, or lack of experience and knowledge, unless they have been given supervision or instruction concerning use of the appliance by a person responsible for their safety.
- Children should be supervised to ensure that they do not play with the appliance.
- Keep all packaging away from children and dispose of it appropriately.

General Safety

- This appliance is intended to be used in household and similar applications such as:
 - Farmhouses; staff kitchen areas in shops, offices and other working environments;
 - By clients in hotels, motels, bed and breakfast and other residential type environments;
 - Catering and similar non-retail applications.
- This type of refrigerator is widely used in places such as hotels, offices, student dormitories and houses. It is mostly suitable for refrigerating and preserving foods such as fruits and beverage. It enjoys the advantages of small size, light weight, low electric consumption and easy use.
- **WARNING:** Keep ventilation openings, in the appliance enclosure or in the built-in structure, clear of obstruction.
- **WARNING:** Do not use mechanical devices or other means to accelerate the defrosting process, other than those recommended by the manufacturer.
- **WARNING:** Do not damage the refrigerant circuit.
- **WARNING:** Do not use electrical appliances inside the food storage compartments of the appliance, unless they are of the type recommended by the manufacturer.
- Do not use water spray and steam to clean the appliance.
- Clean the appliance with a moist soft cloth. Only use neutral detergents. Do not use abrasive products, abrasive cleaning pads, solvents or metal objects.
- Do not store explosive substances such as aerosol cans with a flammable propellant in this appliance.
- If the supply cord is damaged, it must be replaced by the manufacturer, its service agent or similarly qualified persons in order to avoid a hazard.

- When positioning the appliance, ensure the supply cord is not trapped or damaged.
- Do not locate multiple portable socket-outlets or portable power supplies at the rear of the appliance.
- Opening the door for long periods can cause a significant increase of the temperature in the compartments of the appliance.
- Clean regularly surfaces that can come in contact with food and accessible drainage systems.
- Clean water tanks if they have not been used for 48 hours; flush the water system connected to a water supply if water has not been drawn for 5 days.
- Store raw meat and fish in suitable containers in the refrigerator, so that it is not in contact with or drip onto other food.
- If the refrigerating appliance is left empty for long periods, switch off, defrost, clean, dry, and leave the door open to prevent mould developing within the appliance.
- Two-star frozen-food compartments are suitable for storing pre-frozen food, storing or making ice-cream and making ice cubes.
- One-, two- and three-star compartments are not suitable for the freezing of fresh food.
- This refrigerating appliance is not suitable for freezing foodstuffs.
- This refrigerating appliance is not intended to be used as a built-in appliance.
- The appliance is equipped with a lamp for interior lighting. Only service is allowed to replace the lighting device. Contact your Authorised Service Centre.
- **WARNING:** To avoid a hazard due to instability of the appliance, it must be fixed in accordance with the instructions.

Safety instructions

Installation

- ⚠ Warning!** Only a qualified person can install this appliance.
- Remove all the packaging and the transit bolts.
 - Do not install or use a damaged appliance.
 - Follow the installation instruction supplied with the appliance.
 - Always take care when moving the appliance as it is heavy. Always use safety gloves and enclosed footwear.
 - Make sure the air can circulate around the appliance.
 - Do not tilt the refrigerator for more than 45° from upright during moving it.
 - Wait at least 4 hours before connecting the appliance to the power supply. This is to allow the oil to flow back in the compressor.
 - Do not install the appliance close to radiators or cookers, oven or hobs.
 - The rear of the appliance must stand against the wall.
 - Do not install the appliance where there is direct sunlight.
 - Do not install this appliance in areas that are too humid or too colds, such as the construction appendices, garages or wine cellars.
 - When you move the appliance, lift it by the front edge to avoid scratching the floor.

Electrical Connection

Warning! Risk of fire and electric shock.

Warning! When positioning the appliance, ensure the supply cord is not trapped or damaged.

Warning! Do not use multi-plug adapters and extension cables.

- The appliance must be earthed.
- Make sure that the parameters on the rating plate are compatible with the electrical ratings of the mains power supply.
- Always use a correctly installed shockproof socket.
- Make sure not to cause damage to the electrical components (e.g. mains plug, mains cable, compressor). Please refer to

www.IKEA.com

and contact our local store for local store phone numbers and opening times or have an electrician to change the electrical components.

- The mains cable must stay below the level of the mains plug.
- Connect the mains plug to the mains socket only at the end of the installation. Make sure that there is access to the mains plug after the installation.
- Do not pull the mains cable to disconnect the appliance. Always pull the mains plug.

Use

⚠ Warning! Risk of injury, burns, electrical shock or fire.



Warning! Risk of fire / Flammable materials

The appliance contains flammable gas, isobutane (R600a), a natural gas with a high level of environmental compatibility. Be careful not to cause damage to the refrigerant circuit containing isobutane.

- The surface of the compressor becomes hot: The surface of the compressor may become hot under normal operation. Do not touch it with hands.
- Do not change the specification of this appliance.
- Do not put electrical appliances (e.g. ice cream makers) in the appliance unless they are stated applicable by the manufacturer.
- If damage occurs to the refrigerant circuit, make sure that there are no flames and sources of ignition in the room. Ventilate the room.
- Do not let hot items to touch the plastic parts of the appliance.
- Do not put soft drinks in the frozen-food compartment. This will create pressure on the drink container.
- Do not store flammable gas and liquid in the appliance.
- Do not put flammable products or items that are wet with flammable products in, near or on the appliance.

- Do not touch the compressor or the condenser. They are hot.
- Do not remove or touch items from the frozen-food compartment if your hands are wet or damp.
- Thawed food should not be put back in the frozen-food compartment.
- Follow the storage instructions on the packaging of frozen food.

Internal lighting

-  **Warning!** Risk of electric shock.
- The lamp is only for interior lighting of the appliance. Do not use it for house lighting.

Care and cleaning

-  **Warning!** Risk of injury or damage to the appliance.
- Before maintenance, deactivate the appliance and disconnect the mains plug from the mains socket.
 - This appliance contains hydrocarbons in the cooling unit. Only a qualified person can do the maintenance and the recharging of the unit.
 - Regularly examine the drain of the appliance and if necessary, clean it. If the drain is blocked, defrosted water collects in the bottom of the appliance.

How to reach us if you need our service

- The IKEA after sales customer service center will assist you on the phone with basic trouble-shooting for your appliances at the time of service call request. Please refer to **www.IKEA.com** and select your local store for local store phone numbers and opening times.

Disposal

-  **Warning!** Risk of injury or suffocation.
- Disconnect the appliance from the mains supply.
 - Cut off the mains cable and discard it.
 - Remove the door to prevent children and pets to be closed inside of the appliance.
 - The refrigerant circuit and the insulation materials of this appliance are ozone-friendly.
 - The insulation foam contains flammable gas. Contact your municipal authority for information on how to discard the appliance correctly.
 - Do not cause damage to the part of the cooling unit that is near the heat exchanger.

Installation

-  **Warning!** Refer to Safety chapters.

Positioning

- Follow the separate Assembly Instructions to install this appliance.
- Do not install it in high temperature of humidity. Place so as to avoid being damaged, dampened and rusted.
- This appliance should be installed in a dry, well ventilated indoor where the ambient temperature corresponds to the climate class indicated on the rating plate of the appliance:

Climate class	Ambient temperature
SN	+10°C to +32°C
N	+16°C to +32°C
ST	+16°C to +38°C
T	+16°C to +43°C

- "SN" indicates that this refrigerating appliance is intended to be used at ambient temperatures ranging from 10 °C to 32 °C.
- "N" indicates that this refrigerating appliance is intended to be used at ambient temperatures ranging from 16 °C to 32 °C.
- "ST" indicates that this refrigerating appliance is intended to be used at ambient temperatures ranging from 16 °C to 38 °C.
- "T" indicates that this refrigerating appliance is intended to be used at ambient temperatures ranging from 16 °C to 43 °C.

-  **Warning!** If the appliance operates outside the rated climate type (ambient temperature range), it may not be able to maintain a satisfactory room temperature.

-  Some functional problems might occur for some types of models when operating

outside of that range. The correct operation can only be guaranteed within the specified temperature range. If you have any doubts regarding installation, please turn to the vendor, to our customer service or to the nearest Authorised Service Centre.

Location

- To ensure best performance, install the appliance well away from sources of heat such as radiators, boilers, direct sunlight etc. Make sure that air can circulate freely around the back of the cabinet.

⚠ Caution! In order to guarantee proper functioning in ambient temperature above 38°C, it is advised to have a 30mm separation between the sides of the appliance and surrounding furniture.

Electrical connection

⚠ Caution! DO NOT REMOVE GROUND PRONG. DO NOT USE AN ADAPTOR. DO NOT USE EXTENSION CORD. Failure to follow these instructions can result in death, fire or electrical shock.

Before plugging in, ensure that the voltage and frequency shown on the rating plate correspond to your domestic power supply.

The appliance must be earthed. The power supply cable plug is provided with a contact for this purpose. If the domestic power supply socket is not earthed, connect the appliance to a separate earth in compliance with current regulations, consulting a qualified electrician.

The manufacture declines all responsibility if the above safety precautions are not observed.

Product description

Carefully read the operating instructions before using the appliance.

- 1** Storage shelves
- 2** Three-star frozen-food compartment
- 3** Temperature regulator and interior lighting
- 4** Variable storage box
- 5** Fruit and vegetable drawer
- 6** Rating plate

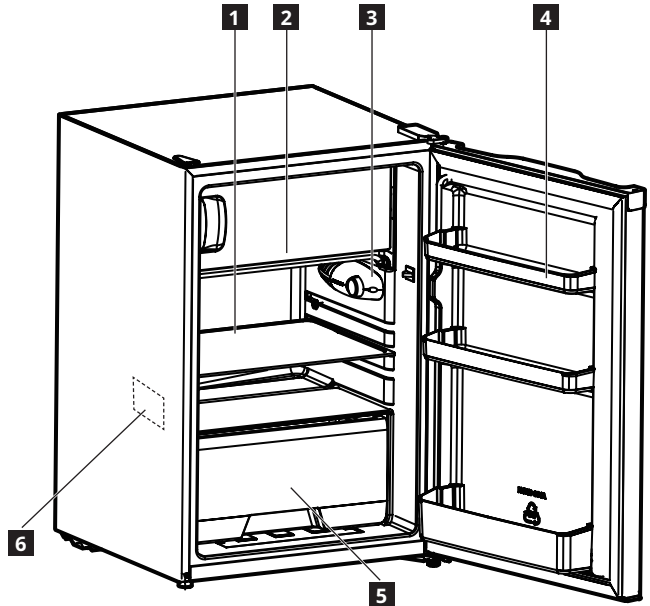

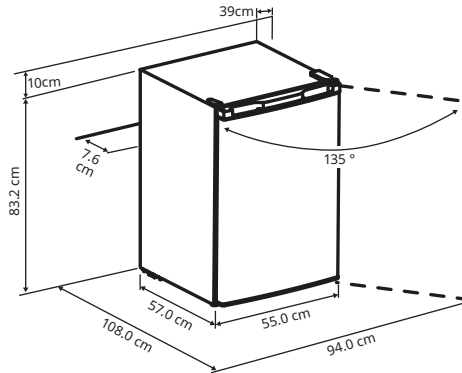

Operation

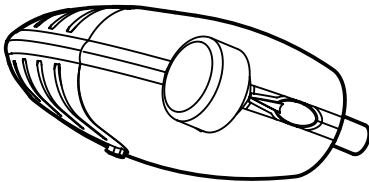

Switching on

Connect the mains plug to the power socket. Set the temperature regulator to a medium setting (Refer to "Temperature regulation").

When operating the appliance for the first time, set the appliance at a colder temperature and run it without loading any food until it auto stops at the set temperature. Usually it takes 2 or 3 hours, then set the temperature regulator at the desired setting and put food in the appliance.

Switching off

To turn off the appliance, turn the temperature regulator to the "OFF" position.

Give the appliance time to cool down completely before adding food. It is best to wait 24 hours before adding food

Temperature regulation

The temperature is automatically regulated. To operate the appliance, proceed as follows:

- Turn the temperature regulator toward lower settings to obtain the minimum coldness.
- Turn the temperature regulator toward higher settings to obtain the maximum coldness.

i A medium setting is generally the most suitable.

Adjust the temperature setting by keeping in mind that the temperature inside the appliance depends on:

- room temperature
- how often the door is opened
- the quantity of food stored
- the location of the appliance

Important! If the ambient temperature is high or the appliance is fully loaded, and the appliance is set to the lowest temperatures, it may run continuously causing frost to form on the rear wall. In this case a higher temperature must be set to allow automatic defrosting and therefore reduced energy consumption.

First use

Cleaning the interior

Before using the appliance for the first time, wash the interior and all internal accessories with lukewarm water and same

neutral soap so as to remove the typical smell of a brand new product, then dry thoroughly.

Important! Do not use detergents or abrasive powders, as these will damage the finish.

Hints and tips

Normal operating sounds

The following sounds are normal during operation:

- A faint gurgling and bubbling sound from coils sound when refrigerant is pumped.
- A whirring and pulsating sound from the compressor when refrigerant is pumped.
- A sudden cracking noise from inside appliance caused by thermic dilatation (a natural and not dangerous physical phenomenon).

Hints for energy saving

- Do not open the door frequently or leave it open longer than absolutely necessary.
- If the ambient temperature is high and very low internal temperature is set and the appliance is fully loaded, the compressor may run continuously, causing frost or ice on the evaporator. If this happens, set the internal temperature toward warmer one to allow automatic defrosting and so a saving in electricity consumption.

Hints for fresh food refrigeration

- Do not store warm food or evaporating liquids in the refrigerator.
- Cover or wrap the food, particularly if it has a strong flavour.
- Position food so that air can circulate freely around it.

Hints for refrigeration

Useful hints:

- Meat (all types): wrap in a suitable packaging and place it on the glass shelf above the vegetable drawer. Store meat for at most 1-2 days.
- Cooked foods, cold dishes: cover and place on any shelf.
- Fruit and vegetables: clean thoroughly and place in a special drawer. Bananas, potatoes, onions and garlic must not be kept in the refrigerator if not packed.
- Butter and cheese: place in a special airtight container or wrap in an aluminium foil or a polythene bag to exclude as much air as possible.
- Bottles: close with a cap and place on the door bottle shelf, or (if available) on the bottle rack.

Cautions for Use

- The more food stuff put in or the more and the longer for once the door is opened, the more it needs electric consumption, which even leads malfunction.
- Re-plug in the power plug at the interval of over ten minutes.
- Do not store bottled drink in the frozen-food compartment, so as to prevent from being broken and damaging the refrigerator.
- Open the door as less as possible during power-cut.
- When defrosting, never use any sharp or metallic objects to remove the frost on the surface of the evaporator as it will damage the evaporator.
- Do not touch foods and containers in the frozen-food compartment with your wet hands so as to prevent from being frostbitten.

Storage of frozen food

- When first starting-up or after a period out of use, before putting the products in the compartment let the appliance run at least 2 hours on the colder setting.
- When you close and seal the package you must not allow air or moisture in or out. If you do, you could have food odour and taste transfer throughout the refrigerator, and also dry out frozen food.
- **Note:** Never put bottled food or drinks in the frozen-food compartment.
- For best performance, leave enough space in the frozen-food compartment for air to circulate around the packages. Also let enough room at the front so the door can close tightly.

Hints for storage of frozen food

To obtain the best performance from this appliance, you should:

- Make sure that the commercially frozen foodstuffs were adequately stored by the retailer.
- Make sure that frozen foodstuffs are transferred from the food store to the frozen-food compartment in the shortest possible time.
- Do not open the door frequently or leave it open longer than absolutely necessary.

- Once defrosted, food deteriorates rapidly and cannot be refrozen.
- Do not exceed the storage period indicated by the food manufacturer.

⚠ Warning! In the event of accidental defrosting, for example due to a power failure, if the power has been off for longer than the value shown in the technical characteristics chart under “rising time”, the defrosted food must be consumed quickly.

Thawing

Deep-frozen or frozen food, prior to being used, can be thawed in the refrigerator compartment or at room temperature, depending on the time available for this operation.

Suggestion: The frozen food should not come into direct contact with the food already stored in the refrigerator. Moreover, if it is necessary to freeze food every day, the quantity of frozen food should be reduced.

Small pieces may even be cooked still frozen, directly from the frozen-food compartment: in this case, cooking will take longer.

Care and cleaning

⚠ Warning! Refer to Safety chapters.

General warnings

- ⚠ Caution!** Unplug the appliance before carrying out any maintenance operation.
- i** This appliance contains hydrocarbons in its cooling unit; maintenance and recharging must therefore only be carried out by authorized technicians.
- i** The accessories and parts of the appliance are not suitable for washing in a dishwasher.

Cleaning the interior

Before using the appliance for the first time, the interior and all internal accessories should be washed with lukewarm water and some neutral soap to remove the typical smell of a brand-new product, then dried thoroughly.

⚠ Caution! Do not use detergents or abrasive powders, as these will damage the finish.

Cleaning the fridge/freezer exterior

Clean the fridge/freezer door exterior using a non-abrasive cloth damped in warm water and mild soap or a cleaning detergent specifically designed for the appliance.

Initial power on

⚠ Caution! Before inserting the power plug in to the outlet and switching on the cabinet for the first time, leave the appliance

standing upright for at least 4 hours. This will assure a sufficient amount of time for the oil to return to the compressor. Otherwise the compressor or electronic components may sustain damage.

Periodic cleaning

- ⚠ Caution!** Do not pull, move or damage any pipes and/or cables inside the cabinet.
- ⚠ Caution!** Do not damage the cooling system.
- ⚠ Caution!** When moving the cabinet, lift it by the front edge to avoid scratching the floor.

The equipment has to be cleaned regularly:

1. Clean the inside and accessories with lukewarm water and some neutral soap.
2. Regularly check the door seals and wipe clean to ensure they are clean and free from debris.
3. Rinse and dry thoroughly.
4. If accessible, clean the condenser and the compressor at the back of the appliance with a brush. This operation will improve the performance of the appliance and save electricity consumption.

Periods of non-operation

When the appliance is not in use for long periods, take the following precautions:

1. Disconnect the appliance from electricity supply.
2. Remove all food.
3. Defrost (if necessary) and clean the appliance and all accessories.
4. Clean the appliance and all accessories.
5. Leave the door/doors open to prevent unpleasant smells.

⚠ Caution! If you want to keep the appliance switched on, ask somebody to check it once in a while to prevent the food inside from spoiling in case of a power failure.

Defrosting fridge compartment

Defrosting process is automatic: the melted frost in the back of the inside flows into the drip tray on the outside and will automatically evaporate.

Defrosting frozen-food compartment

Due to seasonal changes, a thick layer of frost may form. To defrost manually, observe the followings.

- Turn the thermostat knob to set at OFF position and leave open the frozen-food compartment door.
- Remove all foods, ice cube tray and shelf or transfer to refrigerator compartment.
- Clean and wipe out the melted frost with a cloth.
- After defrosting, turn thermostat knob to origin position.
- During manual defrosting, maintenance or cleaning, the temperature rise of the frozen food may shorten its storage period.

⚠ Caution! To avoid damaging the frozen-food compartment wall, do not use any sharp objects to remove the frost or separate the frozen food.

Troubleshooting

⚠ Warning! Refer to Safety chapters.

What to do if...

Problem	Possible Cause	Solution
The appliance does not operate.	The appliance is switched off.	Switch on the appliance.
	The mains plug is not connected to the mains socket correctly.	Connect the mains plug to the mains socket correctly.
	The appliance has no power. There is no voltage in the mains socket.	Connect a different electrical appliance to the mains socket. Contact a qualified electrician.
The appliance is noisy.	The appliance is not supported properly.	Check if the appliance stands stable.
The lamp does not work.	The lamp is defective.	Contact the nearest IKEA store.
The compressor operates continually.	Temperature is set incorrectly.	Refer to "Operation" chapter.
	Many food products were inserted at the same time.	Wait some hours and then check the temperature again.
	The room temperature is too high.	Refer to climate class chart on the rating plate.
	Food products placed in the appliance were too warm.	Allow food products to cool to room temperature before storing.
	The door is not closed correctly.	Refer to "Closing the door".

Problem	Possible Cause	Solution
The temperature in the appliance is too low/too high.	The temperature is not set correctly.	Set a higher/lower temperature.
	The door is not closed correctly.	Refer to "Closing the door".
	The food products temperature is too high.	Let the food products temperature decrease to room temperature before storage.
	Many food products are inserted at the same time.	Insert less food products at the same time.
	The thickness of the frost is greater than 4-5 mm.	Defrost the appliance.
	The door has been opened often.	Open the door only if necessary.
	There is no cold air circulation in the appliance.	Make sure that there is cold air circulation in the appliance.
Food in the refrigerator compartment is freezing.	The thermostat knob is set too cold.	Turn the thermostat knob to a lower setting (higher temperature).
	The position of food stored touches the refrigerant power of the refrigerator back wall.	Move food away from the back wall.
Food in the refrigerator compartment is not cold.	The air vents are blocked in the compartment. This prevents the movement of cold air.	Make sure air can circulate inside.
	The door(s) are opened too often or not close properly.	Avoid frequent openings of the fridge door.
	A large amount of food has just been added to the refrigerator or refrigerator compartment.	Load with less amount food at the time.
	The position of thermostat knob is adjusted too low.	Turn the thermostat knob to a higher setting (lower temperature).
Melted frost leak over compartment inside or floor.	The drain – off mouth entrance is blocked.	Use the cleaning spout to clear blockage.
There is interior moisture build - up.	The air vents are blocked in the refrigerator.	Make sure air can circulate inside.
	The door is opened often.	Avoid frequent openings of the fridge door.
	The food is not packaged correctly.	Make sure foods are packed correctly.
	The temperature is not set correctly of the surrounding conditions.	Turn the thermostat knob to a higher setting (lower temperature).
The door does not close completely.	The shelves are out of position.	Make sure the shelves are in correct position.
	The door gaskets are dirty.	Clean the door gaskets.
	The appliance is not level.	Make sure the appliances is installed in level.

- i** If your appliance still is not working properly after making the above checks, contact the nearest IKEA store.

Closing the door

- Clean the door gaskets.
- If necessary, adjust the door. Refer to the separate Assembly Instructions.
- If necessary, replace the defective door gaskets. Contact the After Sales Service.

Replacing the lamp

The appliance is equipped with a lamp for interior lighting.

Only service is allowed to replace the lighting device.

Please reach out to IKEA, referring to **www.IKEA.com** and select your local store for local store phone numbers and opening times.

Technical information

Product category	
Product type	Refrigerator
Installation type	Freestanding
Product dimensions	
Height	832 mm
Width	550 mm
Depth	570 mm
Net volume	
Fridge	97 L
Three-star frozen-food compartment	16 L
Defrost system	
Fridge	Manual
Frozen-food compartment	Manual
Energy consumption	0.51kW-h/24h
Energy class	Class 3 (GB 12021.2-2015)
Voltage	220 V~
Frequency	50 Hz
Energy consumption	186 kW-h/a
Cooling capacity of refrigeration room	4 kg/12h
Freezing capacity of freezer room	1 kg/12h
Noise level	39 dB(A)

- i** The article number and the serial number are situated in the rating plate on the internal left side of the appliance.

Article Number (8-digit code) *



Serial Number (start with SN, 22-digit code) **

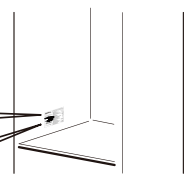

Picture for reference only

Hazardous substances in the product

List of hazardous substances in the product										
Part name	Hazardous substance									
	Lead (Pb)	Mercury (Hg)	Cadmium (Cd)	Hexavalent chromium (Cr(VI))	Polybrominated biphenyls (PBBs)	Polybrominated diphenyl ethers (PBDEs)	Di-n-butyl phthalate (DBP)	Diisobutyl phthalate (DIBP)	Benzyl butyl phthalate (BBP)	Di(2-ethylhexyl) phthalate (DEHP)
Cabinet and its components	○	○	○	○	○	○	○	○	○	○
Doors and their components	○	○	○	○	○	○	○	○	○	○
Compressor components and accessories	✕	○	○	○	○	○	○	○	○	○
PCB	✕	○	○	○	○	○	○	○	○	○
Refrigeration piping parts	○	○	○	○	○	○	○	○	○	○
Refrigerant	○	○	○	○	○	○	○	○	○	○
Electrical components	✕	○	○	○	○	○	○	○	○	○
Packaging and printed components	○	○	○	○	○	○	○	○	○	○
Auxiliary materials	○	○	○	○	○	○	○	○	○	○

Explanation of symbols:
 ○ : Indicates that the content of the hazardous substance in all homogeneous materials of the part does not exceed the requirement of the national standard for the restriction of the use of hazardous substances in electrical and electronic products.
 ✕ : Indicates that the content of the hazardous substance in at least one homogeneous material of the part exceeds the requirement of the national standard for the restriction of the use of hazardous substances in electrical and electronic products.

Note: For those parts not listed above, the content of all hazardous substances in them does not exceed the requirements of the national standard for the restriction of the use of hazardous substances in electrical and electronic products.

Environmental requirements

Please recycle materials marked with the symbol ♻️. Please put the packaging in the corresponding container for recycling. Please protect the environment and human health by recycling used and scrapped electrical and electronic devices. Do not dispose of this product together with ordinary domestic waste. Please send the product to a local recycling facility or contact your municipal office for directions.



Food Contact List



Note

- The components in the food contact list include parts of different product models. Please refer to the actual items for specifics.

List of Food Contact Materials for Refrigerators

Part name	Part materials	Standards used	Part name	Part materials	Standards used
Liner	PS	GB4806.1 GB4806.7	Temperature control box, Knob, Lampshade	ABS, PS, PMMA	GB4806.1 GB4806.7 GB4806.14
Drawers, Vegetable drawers, Bottle balconies, Storage boxes	PS, PP	GB4806.1 GB4806.7 GB4806.14	Supports, Drip trays, Hooks, Plastic bars, Screw caps	PP, ABS, PS	GB4806.1 GB4806.7
Glass shelf components	Glass, PS, ABS, PP	GB4806.1 GB4806.7 GB4806.5 GB4806.14	Plastic-coated shelf	Carbon structural steel Q195/PE	GB4806.1 GB4806.7 GB4806.9
Air duct components	PS	GB4806.1 GB4806.7	Blow-up evaporator	Aluminum 1060 / Polyester resin	GB4806.1 GB4806.13 GB4806.7 GB4806.9
Small door assembly, Inner door seal	PS, TPE	GB4806.1 GB4806.7	Labels	OPP, PET	GB4806.1 GB4806.7

Note: The parts in the detailed list are a summary of the main parts included in different product models. Some materials include but are not limited to those listed herein. Whether this product contains a given part is subject to the product's actual configuration.

IKEA guarantee

How long is the IKEA guarantee valid?

This guarantee is valid for **five (5) years** from the original date of purchase of your appliance at IKEA. The original sales receipt is required as proof of purchase. If service work is carried out under guarantee, it will not extend the guarantee period for the appliance.

Which LAGAN appliances are not covered by the IKEA 5-year guarantee?

LAGAN appliances purchased from IKEA before 1 May 2026 are covered by a 2-year guarantee, starting from the original date of purchase.

Who will execute the service?

IKEA service provider will provide the service through its own service operations or authorized service partner network.

What does this guarantee cover?

The guarantee covers faults of the appliance, which have been caused by faulty construction or material faults from the date of purchase from IKEA. This guarantee applies to domestic use only. The exceptions are specified under the headline "What is not covered under this guarantee?" Within the guarantee period, the costs to remedy the fault e.g. repairs, parts, labour and travel will be covered, provided that the appliance is accessible for repair without special expenditure. On these conditions the respective local regulations are applicable. Replaced parts become the property of IKEA.

What will IKEA do to correct the problem?

IKEA appointed Service Provider will examine the product and decide, at its sole discretion, if it is covered under this guarantee. If considered covered, IKEA Service Provider or its authorized service partner through its own service operations, will then, at its sole discretion, either repair the defective product or replace it with the same or a comparable product.

What is not covered under this guarantee?

- Normal wear and tear.
- Deliberate or negligent damage, damage caused by failure to observe operating instructions, incorrect installation or by connection to the wrong voltage, damage caused by chemical or electro-chemical reaction, rust, corrosion or water damage including but not limited to damage caused by excessive lime in the water supply, damage caused by abnormal environmental conditions.
- Consumable parts including batteries and lamps.
- Non-functional and decorative parts which do not affect normal use of the appliance, including any scratches and possible color differences.
- Accidental damage caused by foreign objects or substances and cleaning or unblocking of filters, drainage systems or soap drawers.
- Damage to the following parts: ceramic glass, accessories, crockery and cutlery baskets, feed and drainage pipes, seals, lamps and lamp covers, screens, knobs, casings and parts of casings. Unless such damages can be proved to have been caused by production faults.
- Cases where no fault could be found during a technician's visit.
- Repairs not carried out by our appointed service providers and/or an authorized service contractual partner or where non-original parts have been used.
- Repairs caused by installation which is faulty or not according to specification.
- The use of the appliance in a non-domestic environment i.e. professional use.
- Transportation damages. If a customer transports the product to his home or another address, IKEA is not liable for any damage that may occur during transport. However, if IKEA delivers the product to the customer's delivery address, then damage to the product that occurs during this delivery will be covered by IKEA.

- Cost for carrying out the initial installation of the IKEA appliance.
- However, if an IKEA appointed Service Provider or its authorized service partner repairs or replaces the appliance under the terms of this guarantee, the appointed Service Provider or its authorized service partner will reinstall the repaired appliance or install the replacement, if necessary.
- All plumbing and electrical installation, are not the responsibility of IKEA, and customer must complete these work before the execution work.

How country law applies

The IKEA warranty gives you specific legal rights, which cover or exceed all the local legal demands. However these conditions do not limit in any way consumer rights described in the local legislation.

Area of validity

This warranty is valid only in the country where the product has been purchased; the services will be provided in the framework of the guarantee conditions. An obligation to carry out services in the framework of the guarantee exists only if the appliance complies and is installed in accordance with:

- the technical specifications of the country in which the guarantee claim is made;
- the Assembly Instructions and User Manual Safety Information;

The dedicated AFTER SALES for IKEA appliances

Please don't hesitate to contact IKEA appointed Authorized Service Centre to:

- make a service request under this guarantee;
- ask for clarifications on installation of the IKEA appliance in the dedicated IKEA kitchen furniture;
- ask for clarification on functions of IKEA appliances.

To ensure that we provide you with the best assistance, please read carefully the Assembly Instructions and/or the User Manual before contacting us.

How to reach us if you need our service

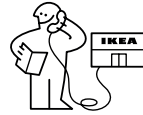

Phone number:

400-800-2345

Opening Hours:

Mon. - Sun.

09:00-21:00

The IKEA after sales customer service center will assist you on the phone with basic troubleshooting for your appliances at the time of service call request.

Please refer to

www.IKEA.com

and select your local store for local store phone numbers and opening times.

Before calling us, assure that You have to hand the IKEA article number (8 digit code) and the Serial Number (8 digit code that can be found on the rating plate) for the appliance of which you need our assistance.

- i SAVE THE SALES RECEIPT!** It is your proof of purchase and required for the guarantee to apply. Note that the receipt reports also the IKEA article name and number (8 digit code) for each of the appliances you have purchased.

Do you need extra help?

For any additional questions not related to After Sales of your appliances please contact your nearest IKEA store call centre. We recommend you read the appliance documentation carefully before contacting us.

