

# FÅGELFJÄLLET

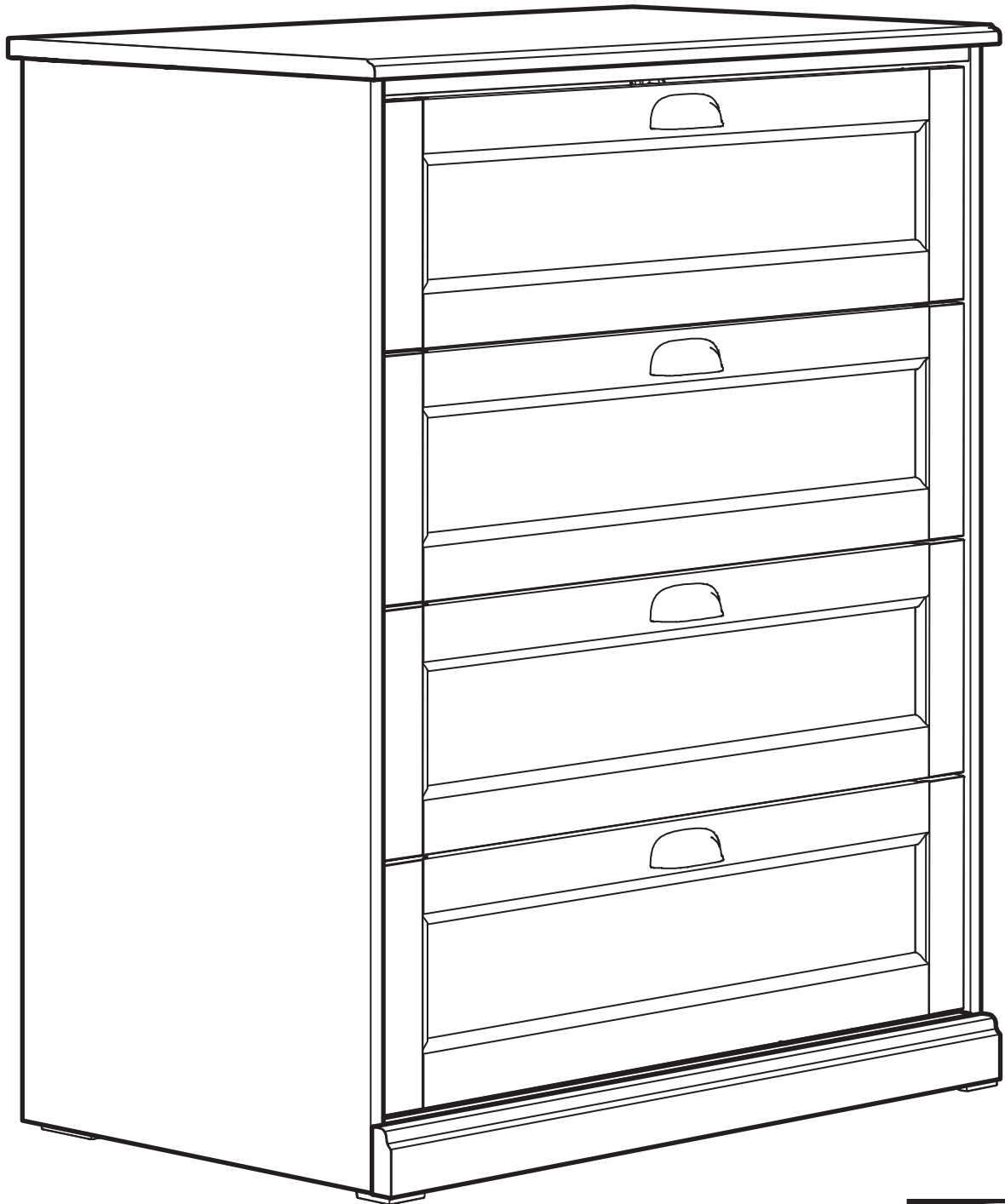

Design and Quality  
IKEA of Sweden

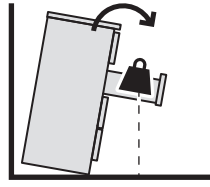
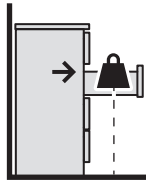

English

## WARNING!

**Serious or fatal crushing injuries can occur from furniture tip-over. To reduce the risk of furniture tip-over:**

ALWAYS secure this furniture to the wall using tip-over restraints.

To further reduce the risk of serious injury and death from tip-overs:

Place heaviest items in the lower drawer.

Do not set TVs or other heavy objects on top of this product.

Never let children climb or hang on drawers, doors, or shelves.

Read and follow each step of the instruction carefully.

Español

## ADVERTENCIA:

**Si el mueble volcase, podría provocar lesiones graves e incluso mortales. Para limitar el riesgo de vuelco de los muebles:**

Fija SIEMPRE el mueble a la pared con herrajes antivuelco.

Para reducir más el riesgo de daños graves o mortales por el vuelco del mueble:

Coloca los objetos más pesados en el cajón inferior.

No pongas la televisión u otros objetos pesados en la parte superior del mueble.

Nunca permitas que los niños trepen o se cuelguen de los cajones, baldas o puertas.

Lee y sigue cada paso de las instrucciones cuidadosamente.

Portugues

## AVISO!

**Podem ocorrer ferimentos graves ou fatais devido à queda de móveis. Para diminuir o risco de queda de móveis:**

Fixe SEMPRE este móvel à parede com acessórios de fixação.

Para reduzir ainda mais o risco de lesões graves e morte devido a queda de móveis:

Coloque os objetos mais pesados nas gavetas mais baixas.

Não coloque televisões ou outros objetos pesados em cima deste artigo.

Nunca permita que as crianças trepem ou se pendurem nas gavetas, portas ou prateleiras.

Leia e siga cuidadosamente as instruções.

中文

## 安全警示!

**家具傾倒可能导致严重或致命的伤害。为降低家具倾倒的风险:**

请务必使用防翻倒约束装置,以便将家具固定在墙面。

为进一步降低家具翻倒而造成的重伤或死亡风险:

请将重物放在低层抽屉中。

请勿将电视机或其它重物放在该产品顶部。

请勿让儿童攀爬或悬挂在抽屉、柜门或搁板上。

请仔细阅读并按照说明中的每个步骤进行操作。

繁中

## 警告!

**家具傾倒可能造成嚴重或致命的傷害。為降低家具傾倒的風險:**

務必使用固定配件將此家具固定在牆上。

家具傾倒或會造成嚴重或致命的傷害:

請將重物放置在底層抽屜。

請勿將電視或其他重物放在此產品的上方。

切勿讓兒童攀爬或懸掛在抽屜、門板或層架上。

請仔細閱讀並依照說明書的步驟。

한국어

## 경고!

**가구 전복 사고가 발생하면 심각한 부상을 입을 수 있습니다. 가구가 넘어질 위험을 줄이려면 다음과 같은 조치를 취하세요.**

가구는 전복 사고 방지용 부품으로 벽에 반드시 고정하세요.

심각한 부상이나 사망에 이를 수 있는 가구 전복 방지를 위해서는 다음과 같이 하세요.

무거운 물건은 아래쪽 서랍에 보관하세요.

본 제품 위에 무거운 물건이나 TV를 두지 마세요.

아이들이 서랍이나 도어, 선반 등을 타고 오르거나 매달리지 않게 하세요.

지침의 각 단계를 자세히 읽고 따르세요.

日本語

## 警告!

**家具の転倒により、家具の下敷きになって大ケガ、あるいは生命にかかわるような傷害を負う危険があります。家具の転倒のリスクを減らすために以下のことを守ってください。**

転倒防止用固定具を用いて、必ず本製品を壁に固定してください。

家具の転倒による重大なケガや死亡事故を防ぐため、

重い物は下段の引き出しに入れてください。

本製品の上にテレビなどの重いものを置かないでください。

安全のため、引き出しや扉、棚の上によじ登ったり、ぶら下がったりしないよう、お子さまにご指導ください。

注意事項をよく読み、手順に従ってください。

Bahasa Indonesia

## PERINGATAN

**Cedera serius dapat terjadi akibat perabot terjatuh. Untuk mengurangi risiko furnitur terjatuh:**

SELALU kencangkan perabot ke dinding dengan menggunakan alat pengencang.

Untuk mengurangi resiko cedera serius dan kematian akibat perabotan terjatuh:

Letakkan benda berat di laci paling bawah.

Jangan meletakkan TV atau benda berat di atas produk ini.

Jangan biarkan anak memanjat atau mengganduli laci, pintu dan rak.

Baca dan ikuti setiap langkah petunjuk dengan seksama.

Bahasa Malaysia

## AMARAN!

**Kecederaan serius atau maut boleh berlaku akibat perabot terbalik. Bagi mengurangkan risiko perabot terbalik:**

SENTIASA kukuhkan perabot ini pada dinding menggunakan penahan rebah.

Bagi mengurangkan lagi risiko kecederaan serius dan kematian akibat terbalik:

Tempatkan barang paling berat di dalam laci paling bawah.

Jangan letakkan TV atau lain-lain objek berat di atas produk ini.

Jangan biarkan kanak-kanak memanjat atau bergayut pada laci, pintu, atau para-para.

Baca dan ikuti setiap langkah arahan dengan teliti.

عربي

## تحذير!

**مخاطر تعرض لإصابات خطيرة نتيجة انقلاب الأثاث. للحد من خطر انقلاب الأثاث:**

يجب تثبيت هذا الأثاث دائماً على الحائط بواسطة أدوات التثبيت.

لتقليل مخاطر الإصابة الخطيرة والتعرض للموت نتيجة انقلاب الأثاث:

يجب وضع الأشياء الثقيلة في الدرج السفلي.

لا يجب وضع تلفزيون أو أي أشياء ثقيلة أخرى فوق هذا المنتج.

يجب عدم السماح للأطفال بتسلق أو التعلق على الأدراج، الأبواب، أو الأرفف.

يرجى قراءة ومتابعة كل خطوة من التعليمات بدقة.





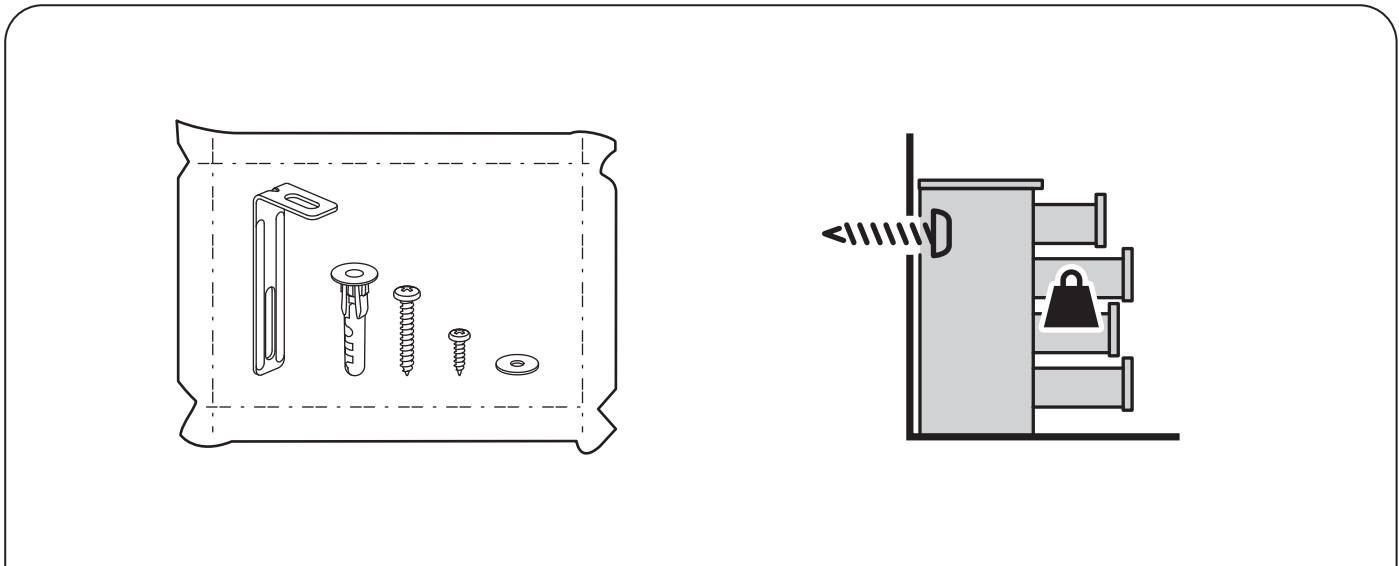
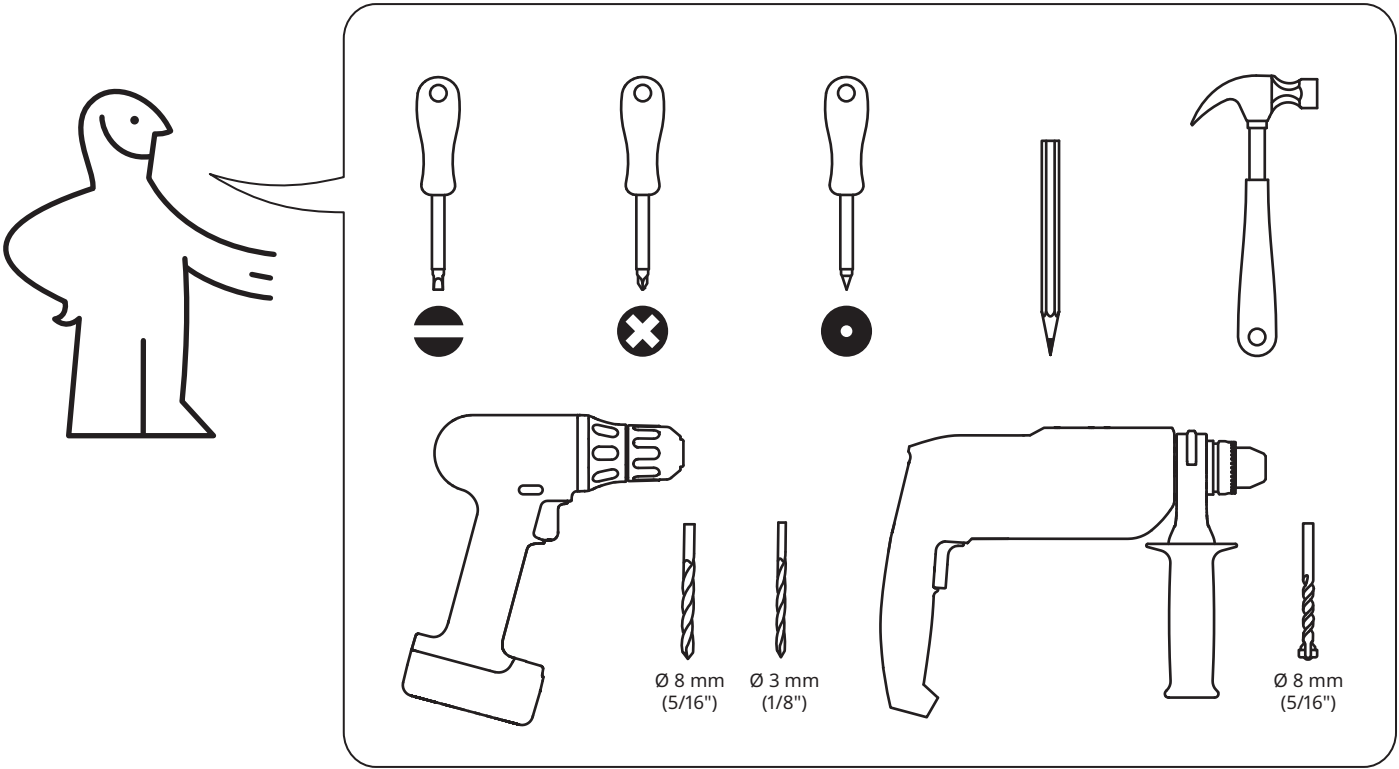

ไทย

## คำเตือน!

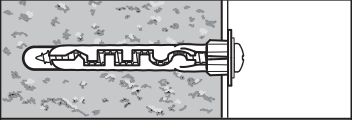
**หากเฟอร์นิเจอร์ล้มคว่ำอาจก่อให้เกิดการบาดเจ็บร้ายแรงหรืออันตรายถึงชีวิตได้ ป้องกันเฟอร์นิเจอร์ล้มโดยปฏิบัติตามดังนี้**

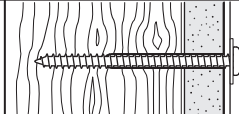
ยึดเฟอร์นิเจอร์เข้ากับผนังเสมอด้วยอุปกรณ์ยึดเพื่อความปลอดภัย

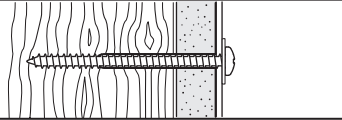

 <p><a href="http://www.IKEA.com/secure-it">www.IKEA.com/secure-it</a></p>	<b>A</b>	<b>B</b>	<b>C</b>
			
	<p>Ø 8 mm (5/16")</p> 	<p>Ø 8 mm (5/16")</p> 	<p>Ø 3 mm (1/8")</p> 

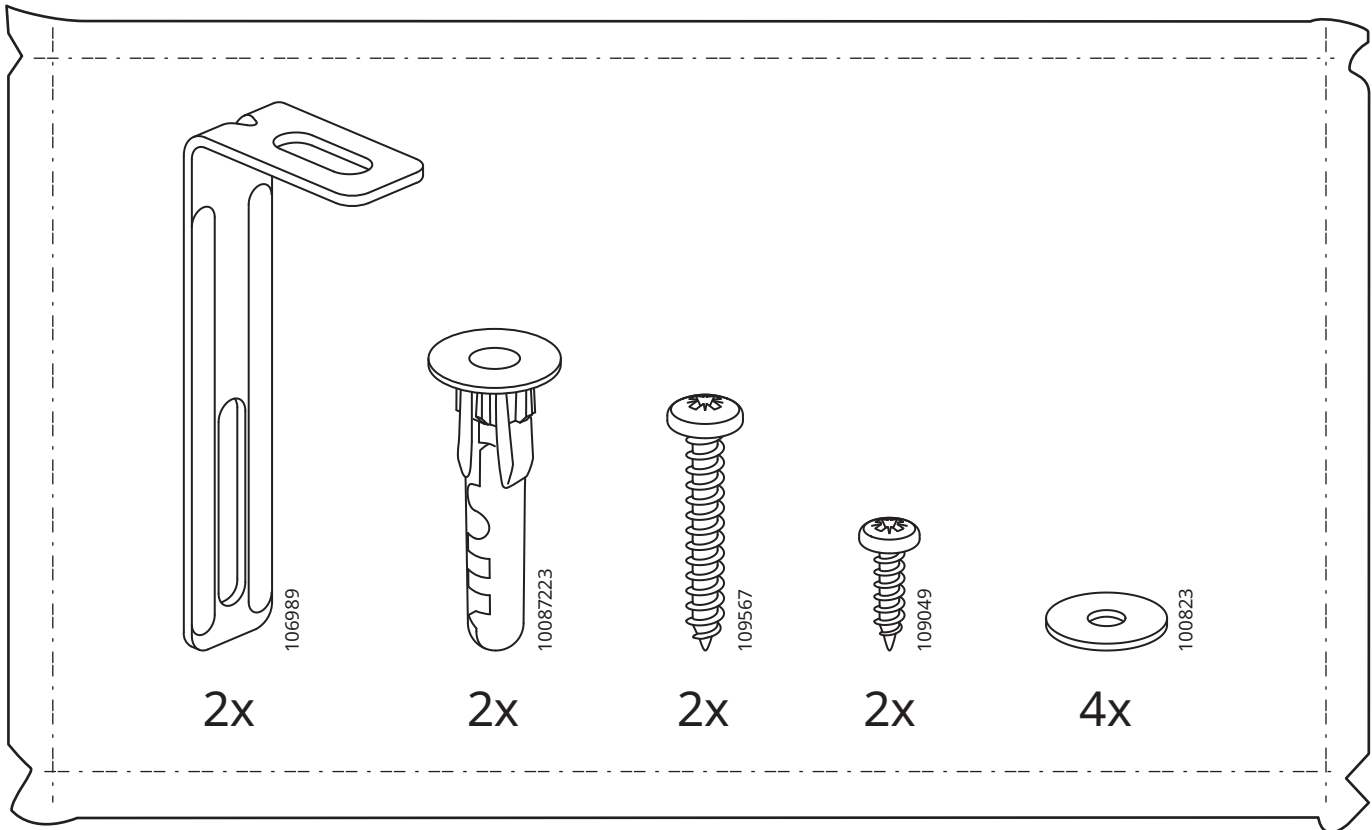
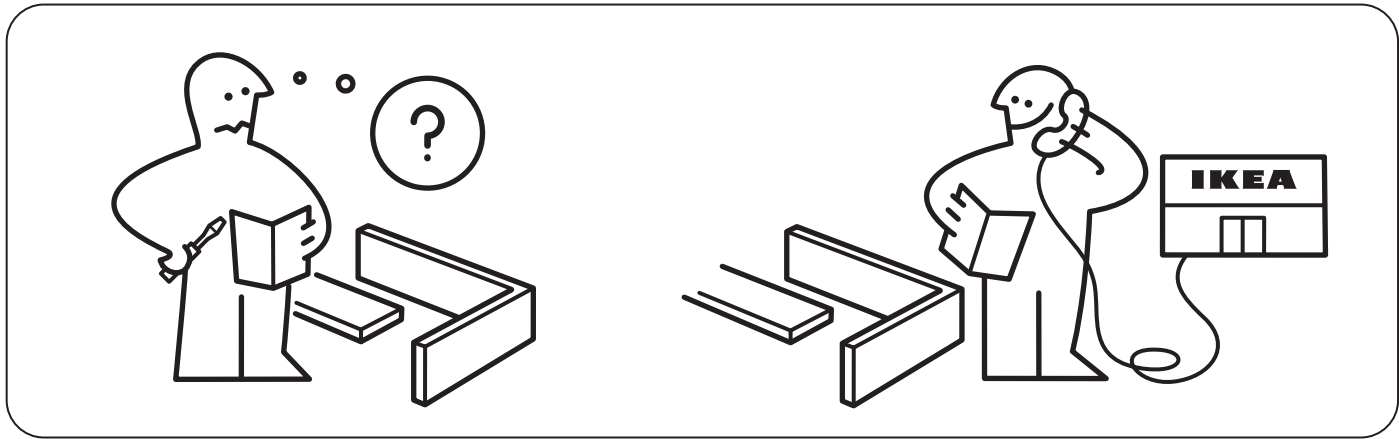
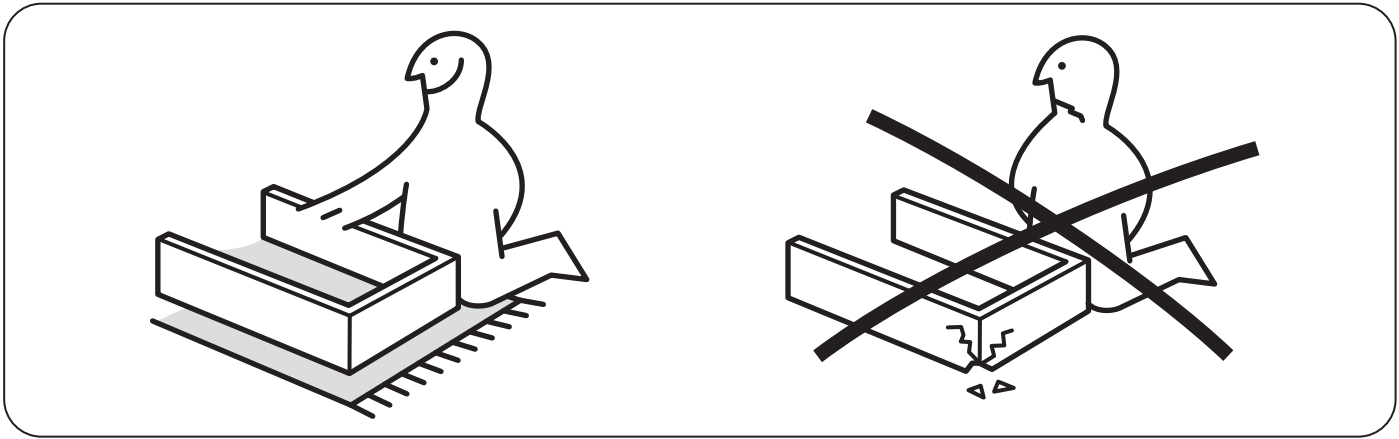

# 1

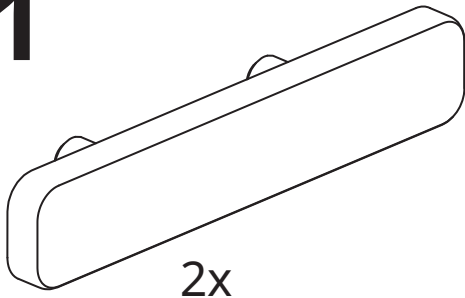

158568  
10127144

2x

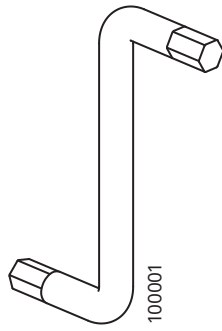

100001

1x

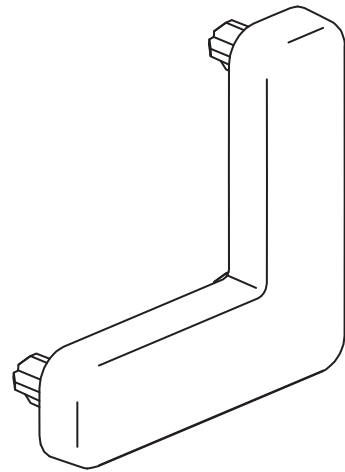

10101849  
10099967

2x

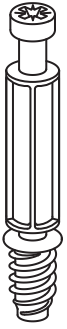

118331

12x

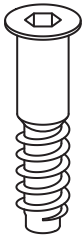

100217

7x



101345

18x

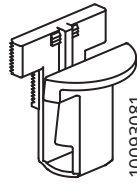

10093081

4x



10093082

12x



119250  
119252

12x



100359

1x



146114

24x

# 2

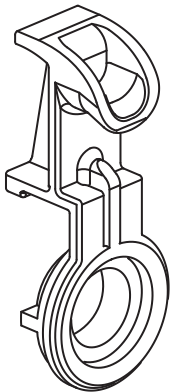

10133139

4x



145718  
159553  
10120234

16x



130449

16x

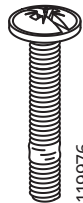

119976

8x

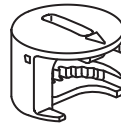

119030  
118224  
117434

32x

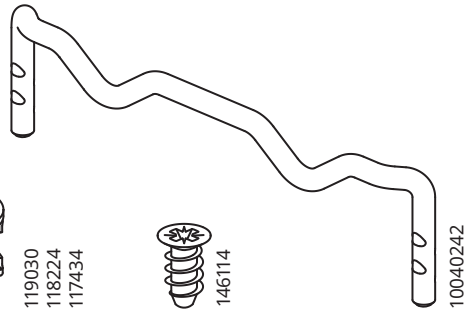

10040242

24x

4x

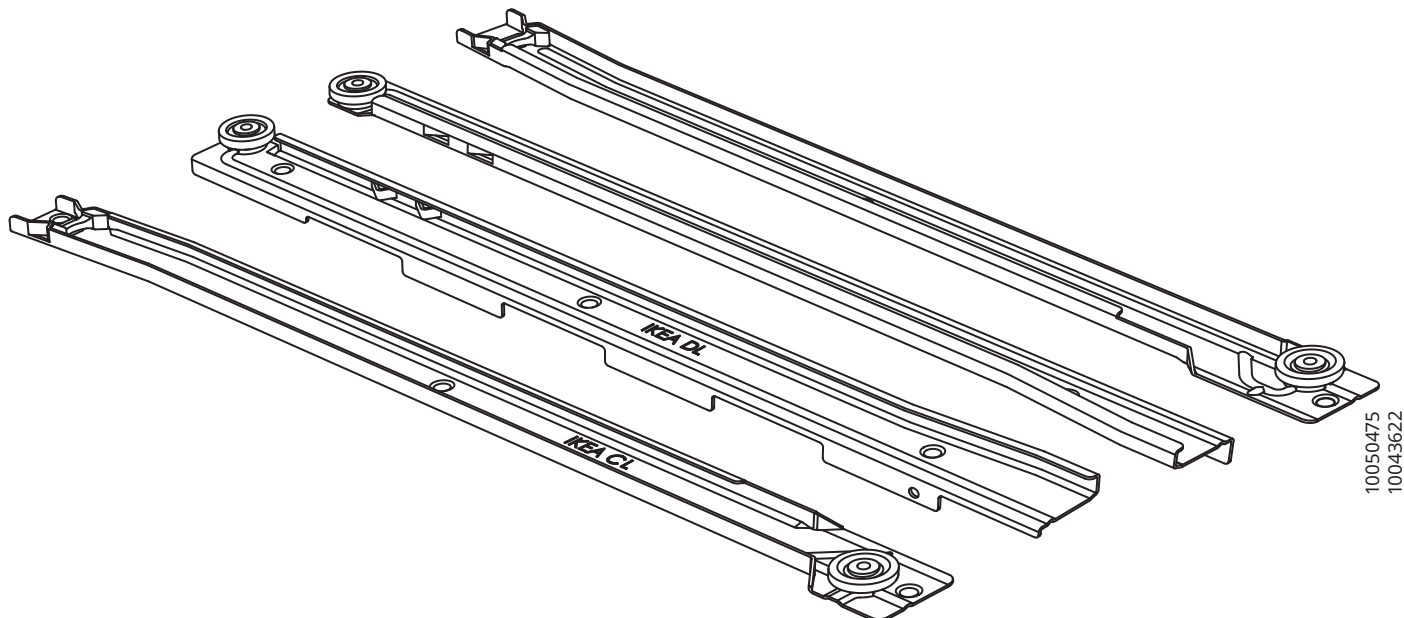

4x

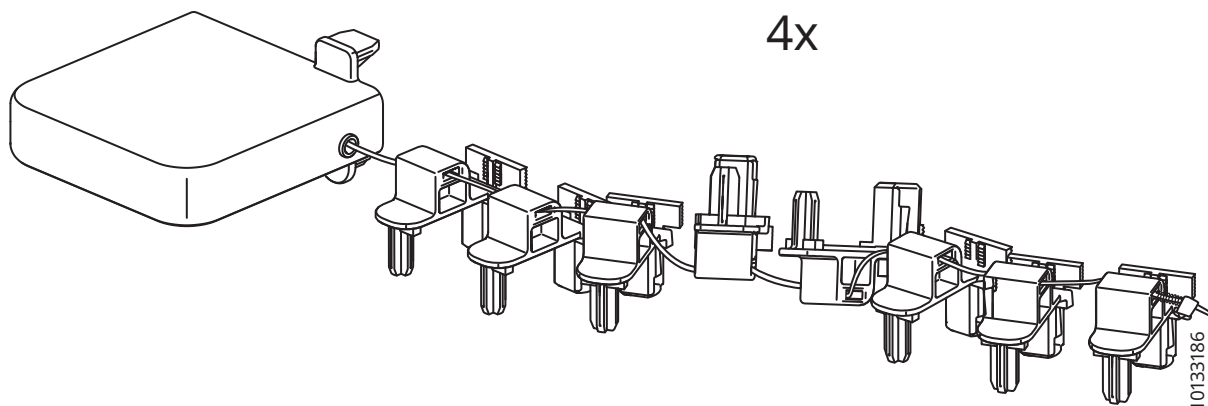

1x

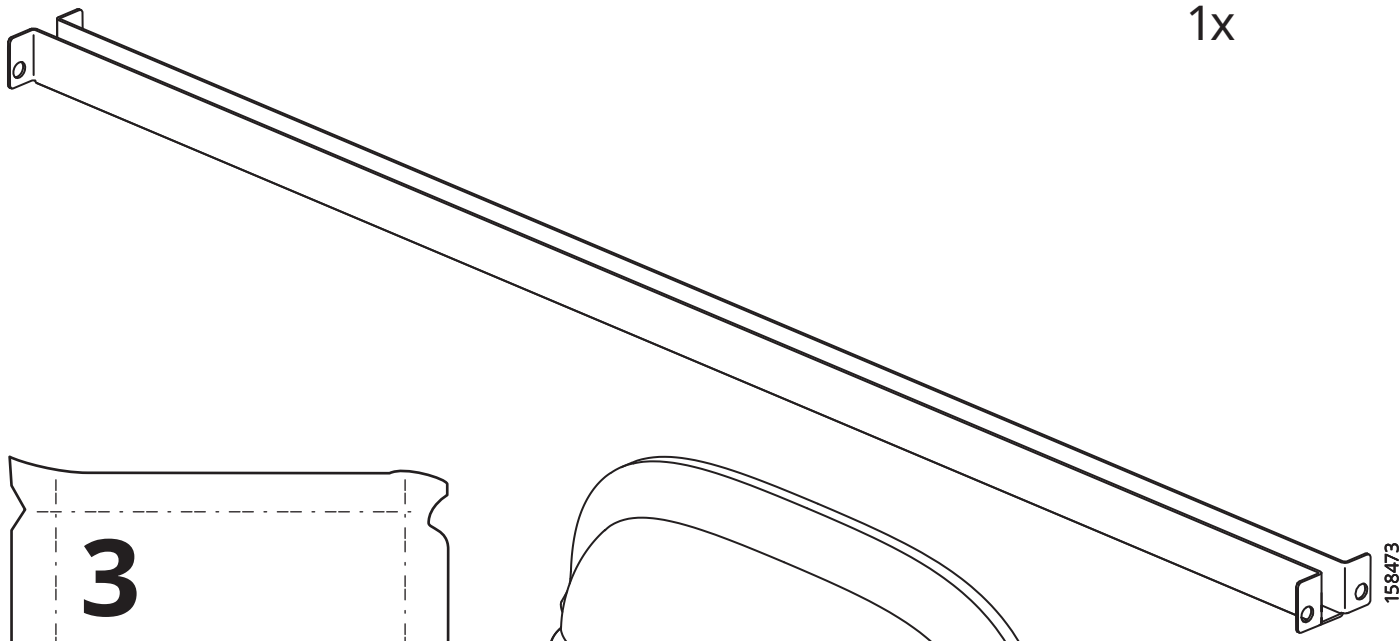

1x

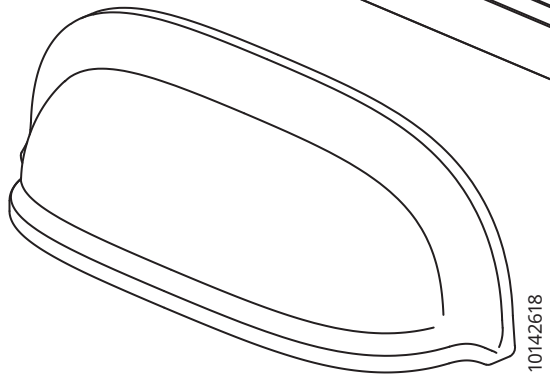
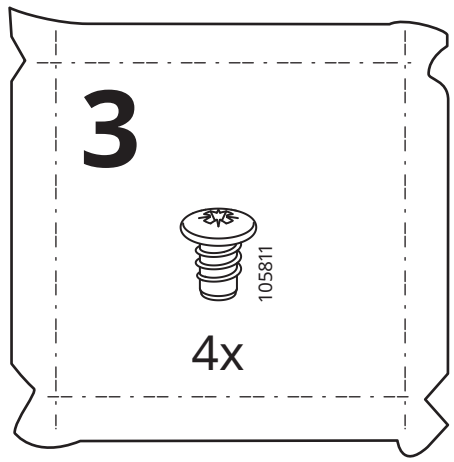

4x

1

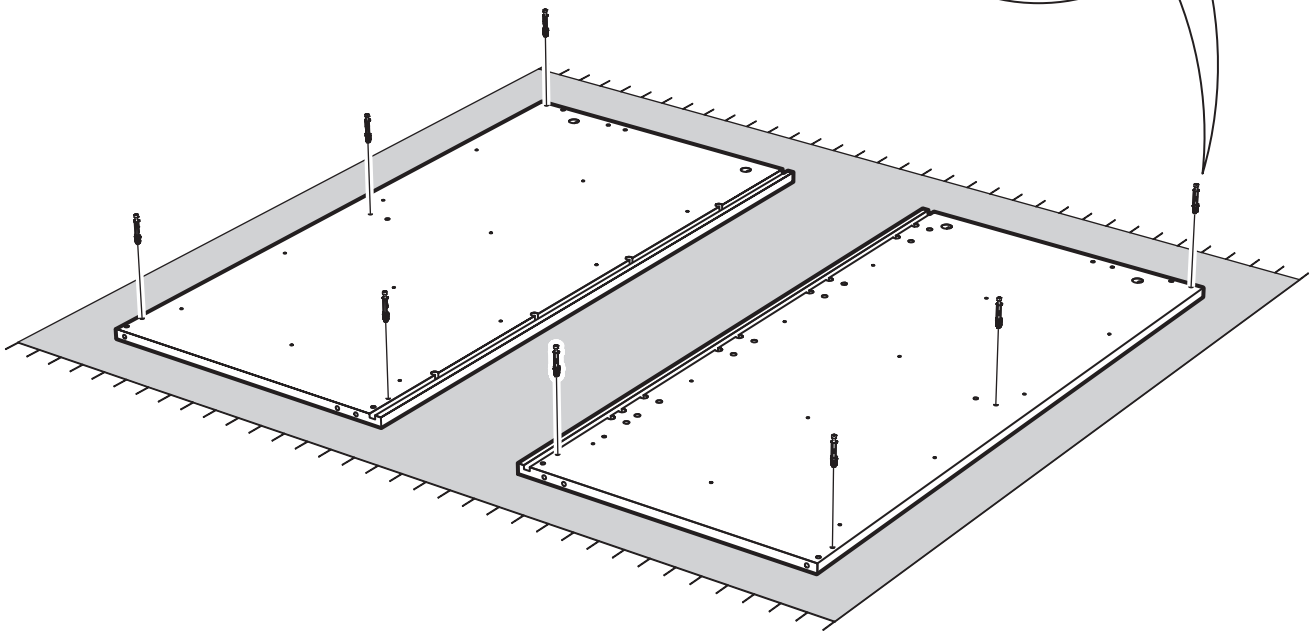
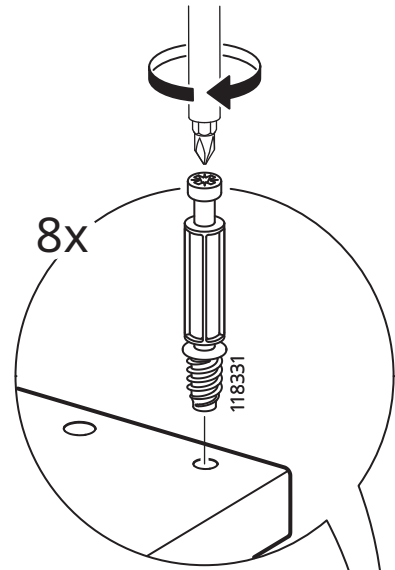

2

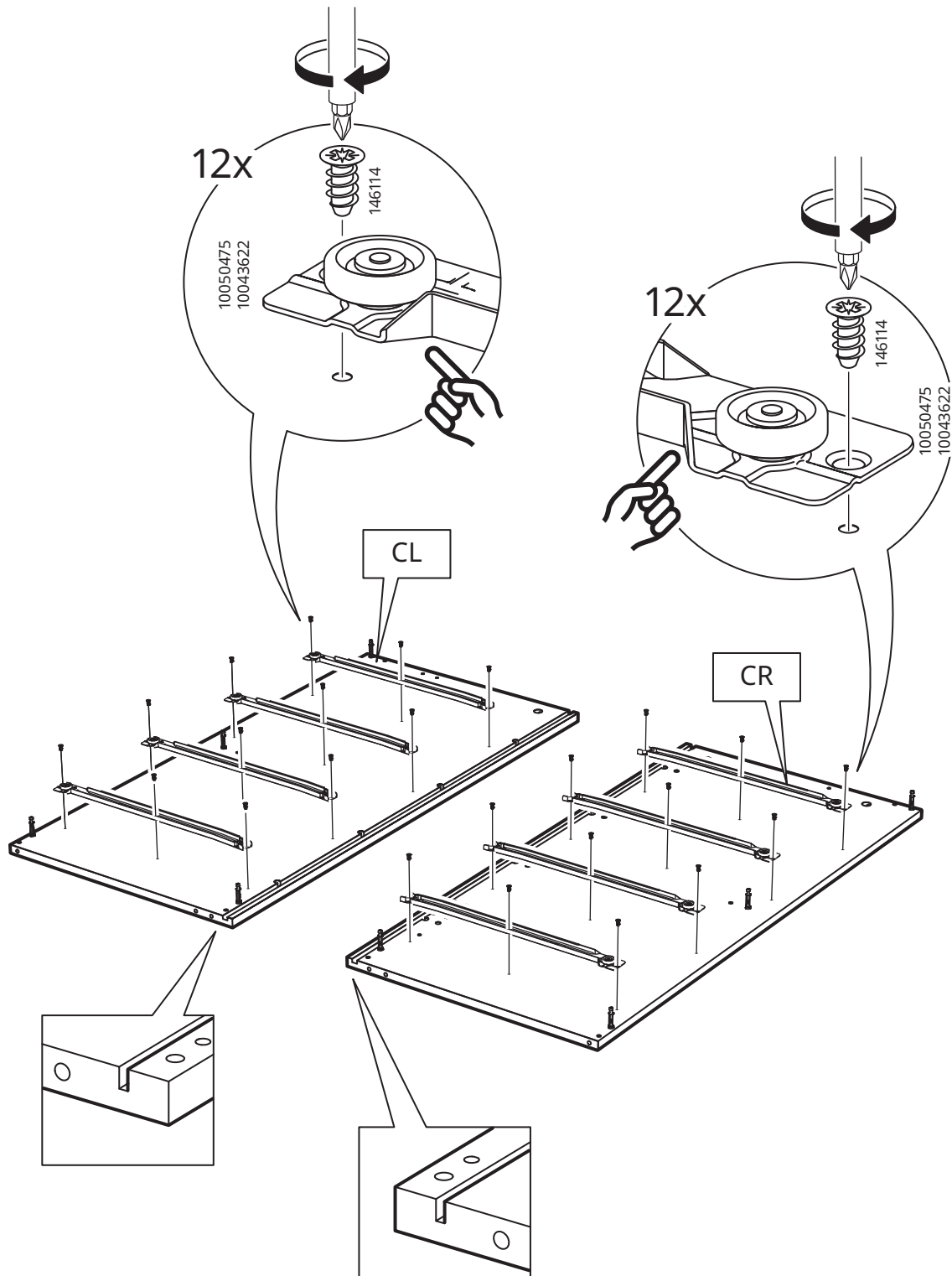

3

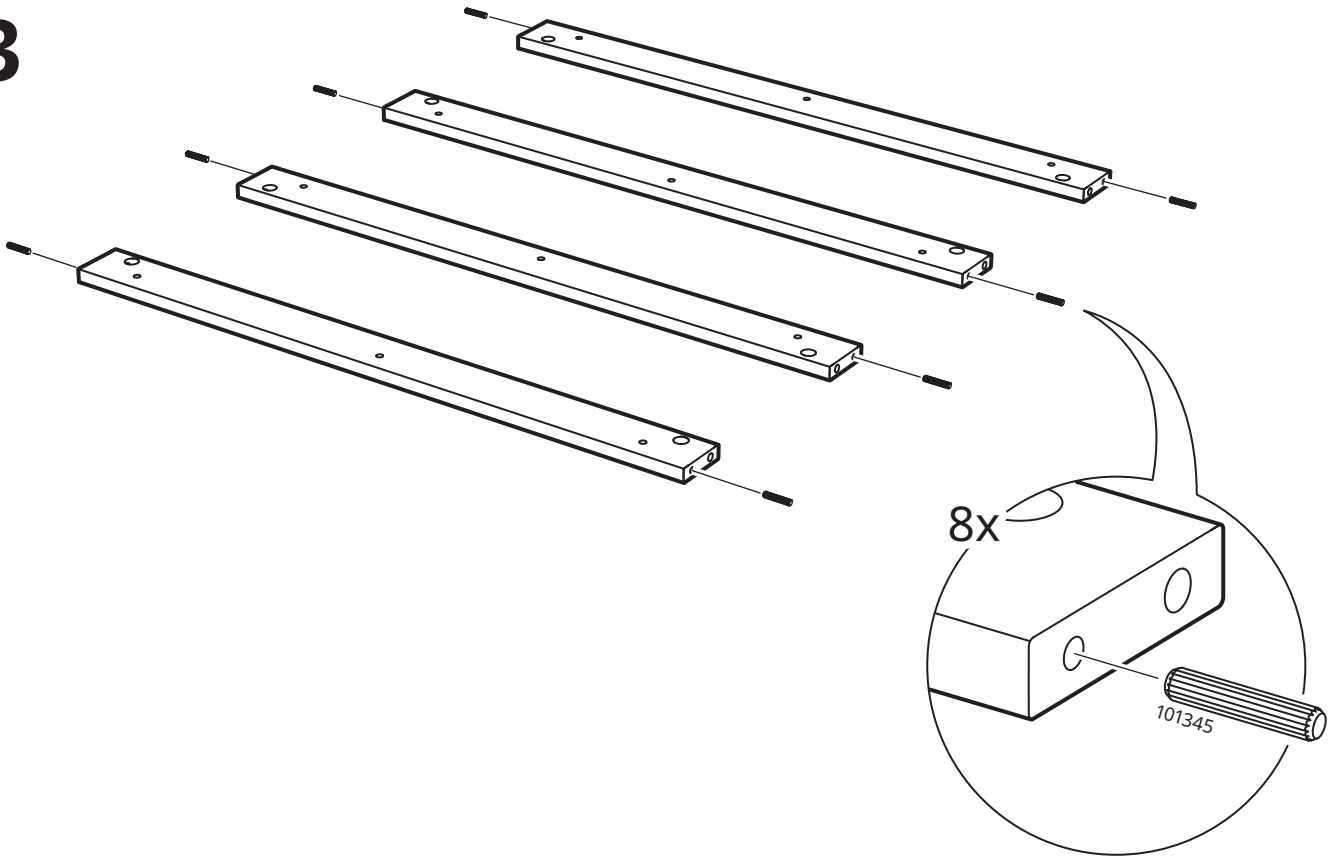

4

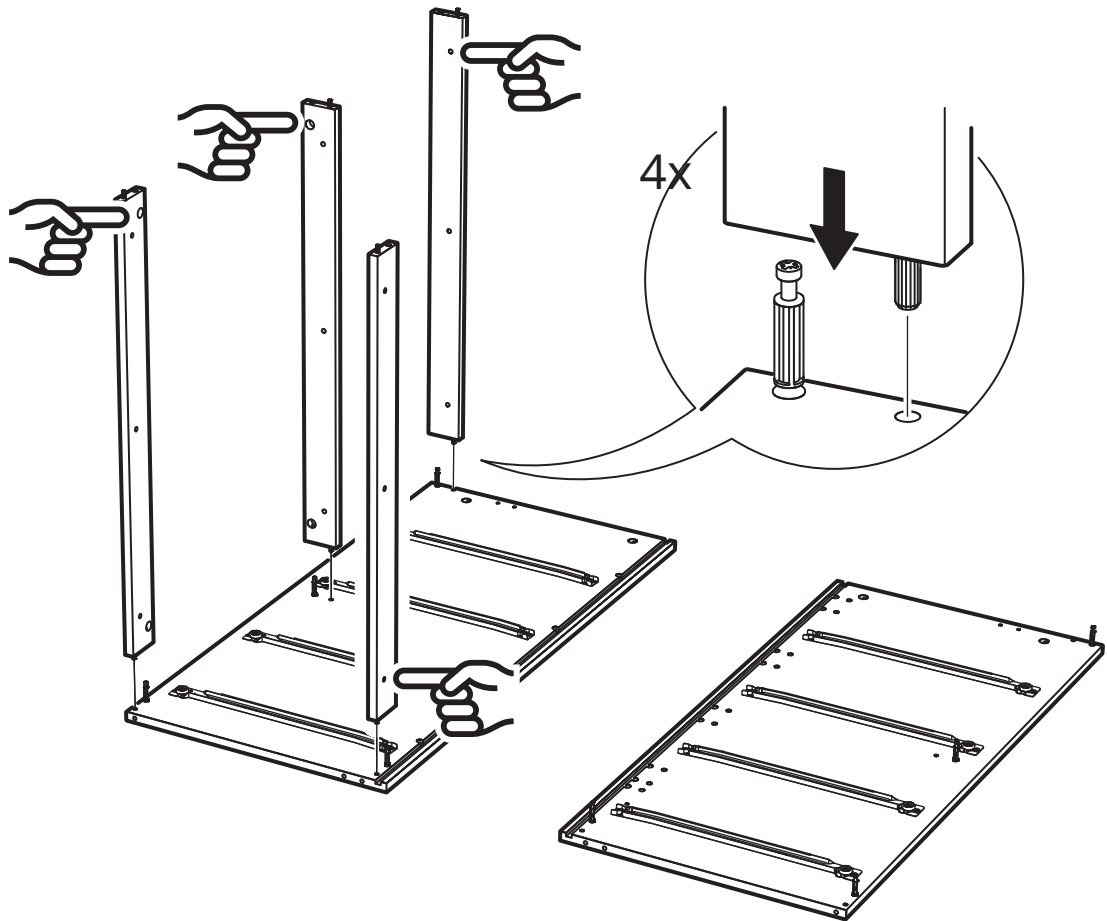

5

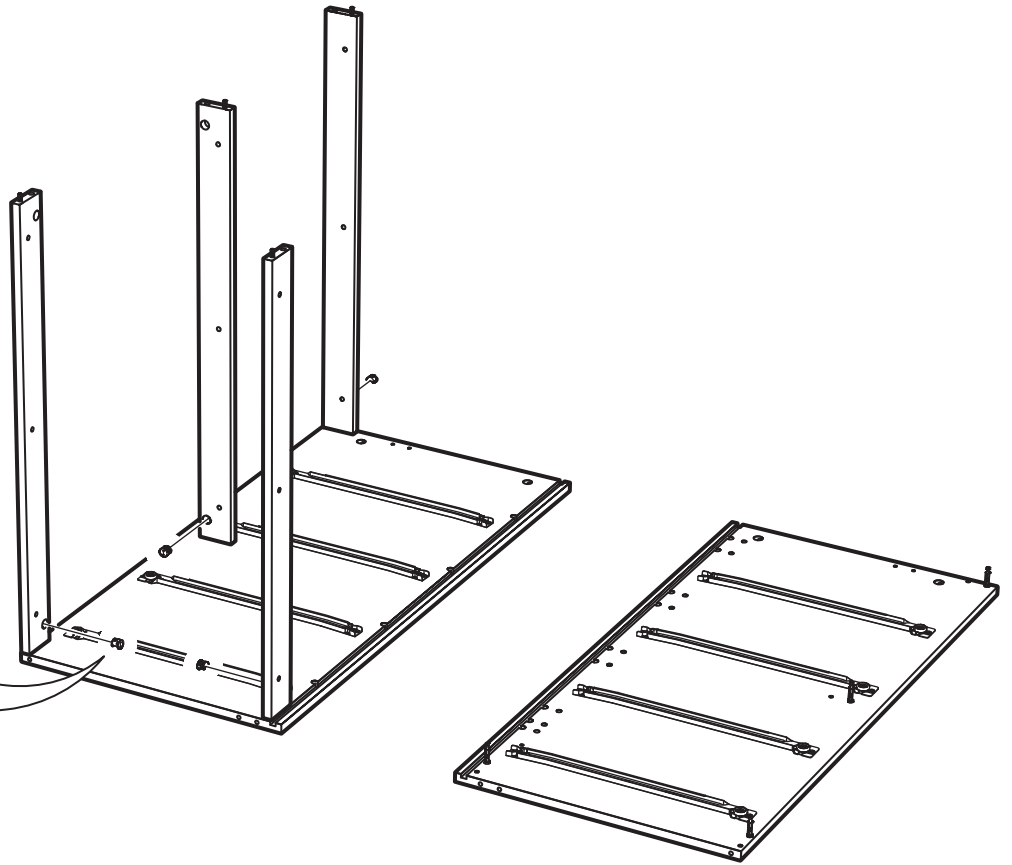
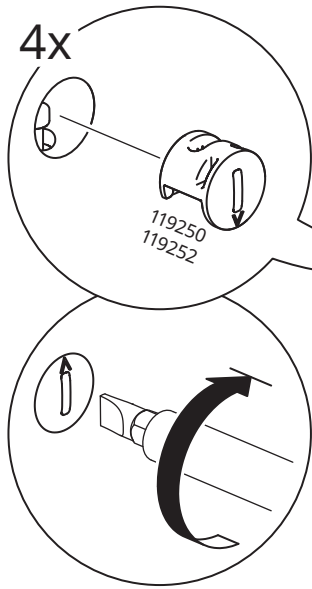

6

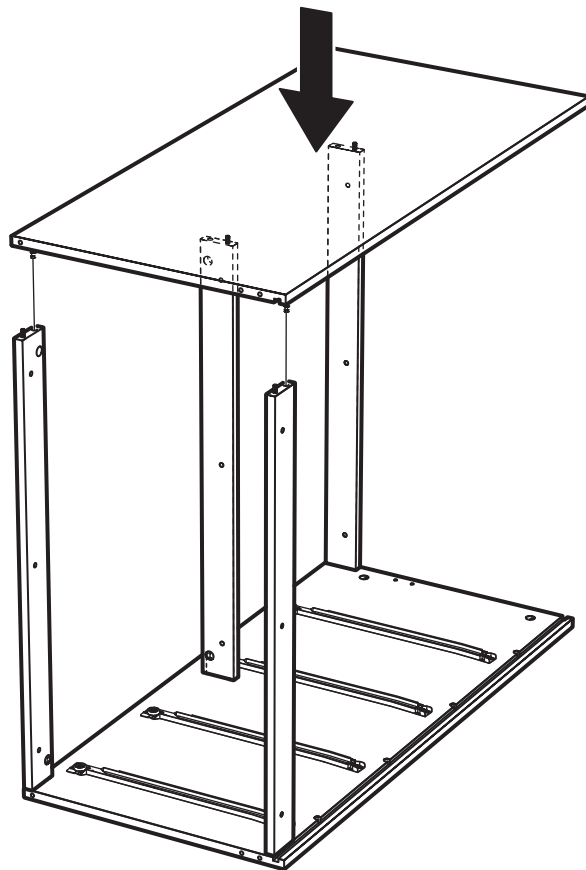

7

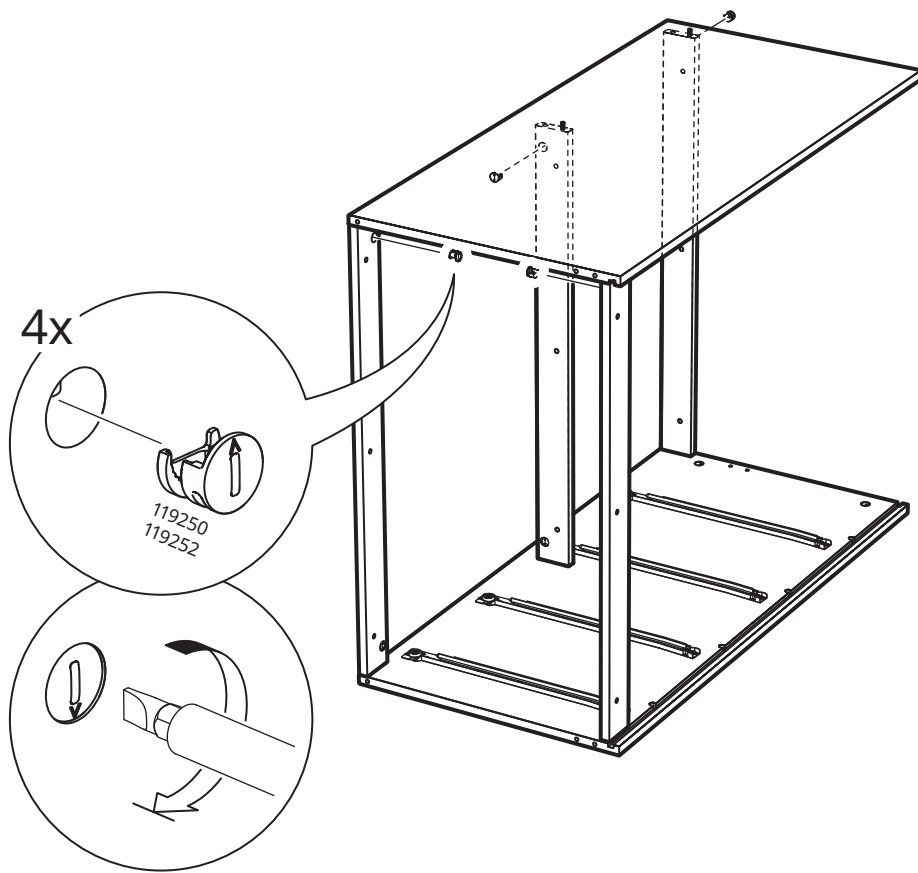

8

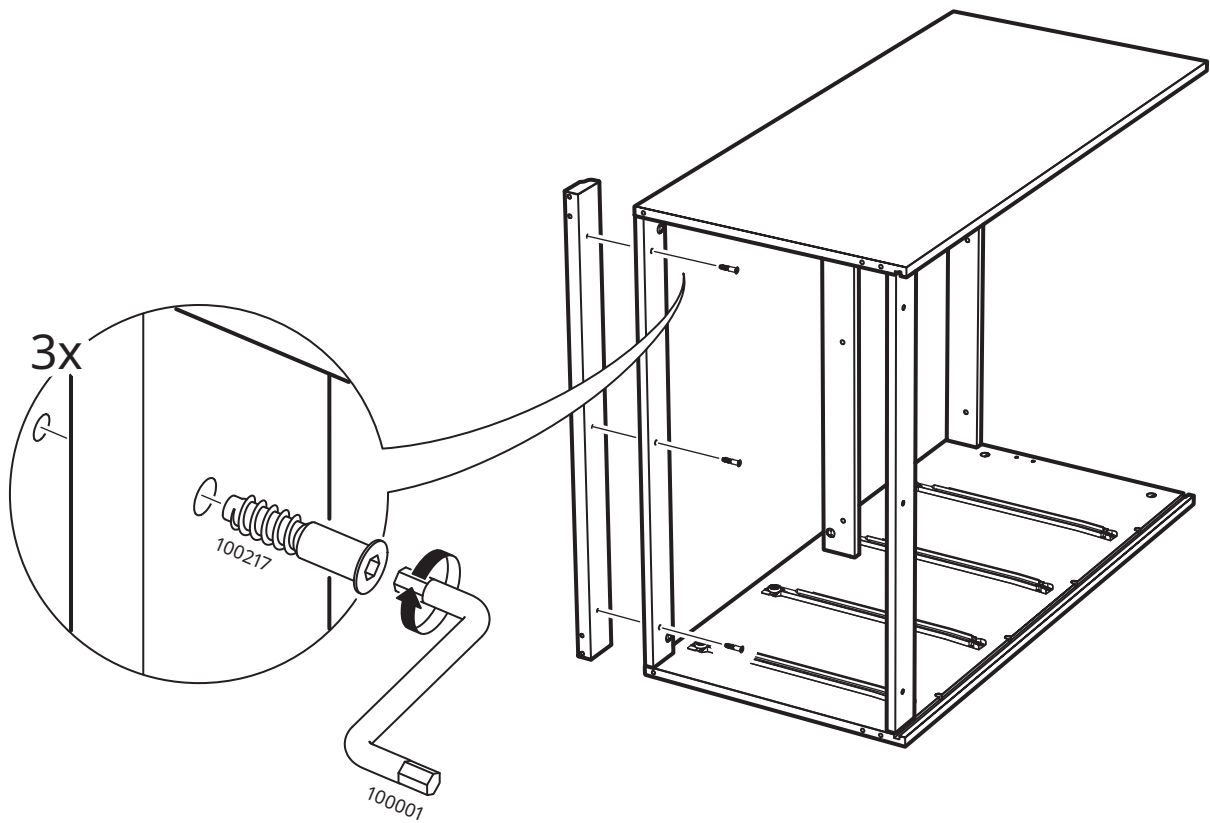

9

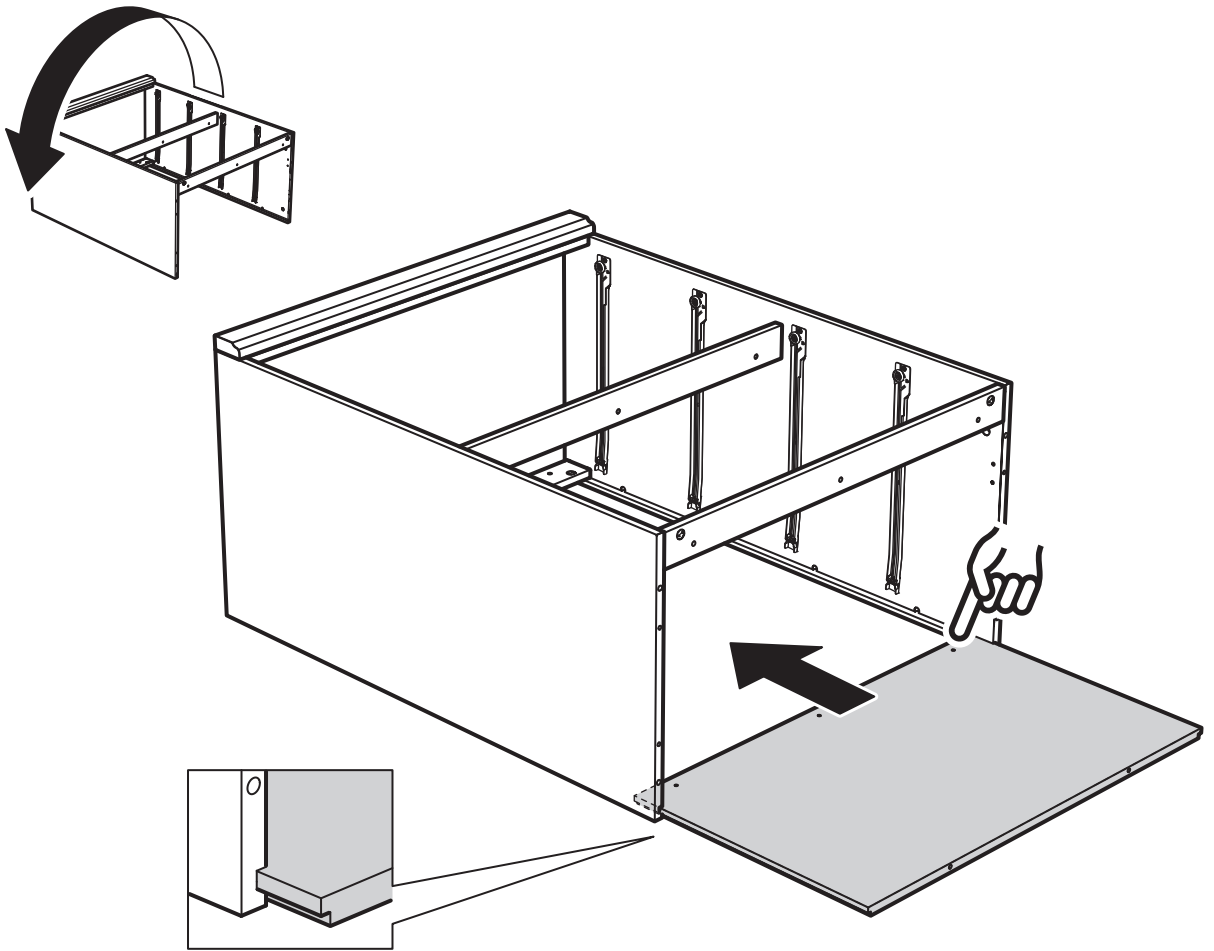

10

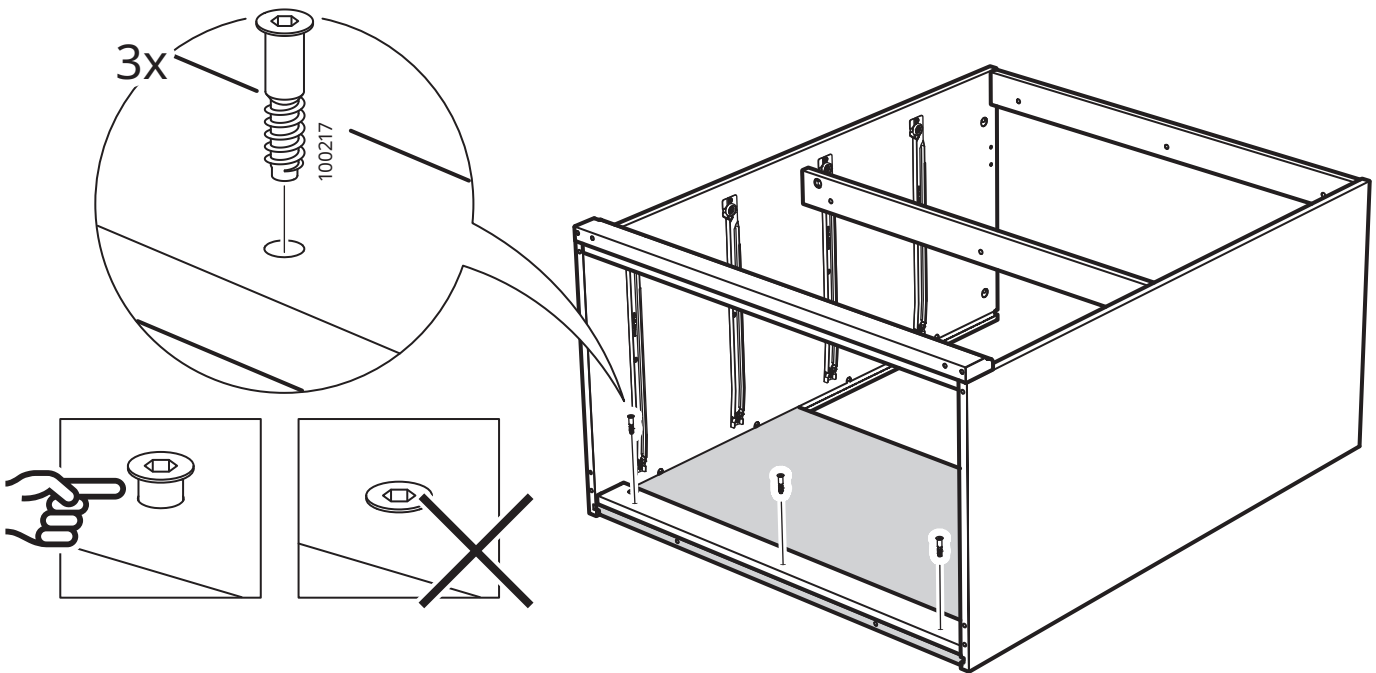

11

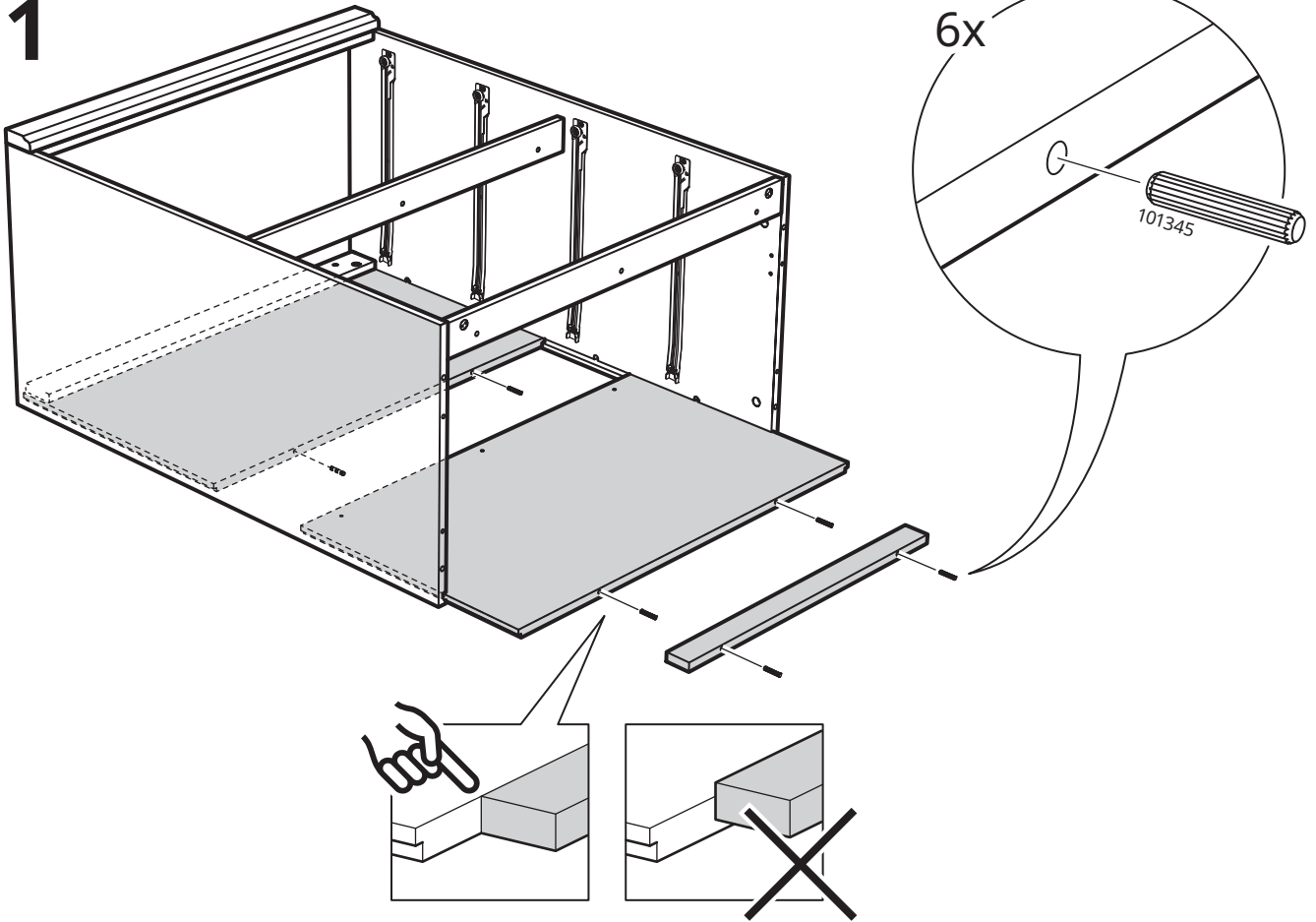

12

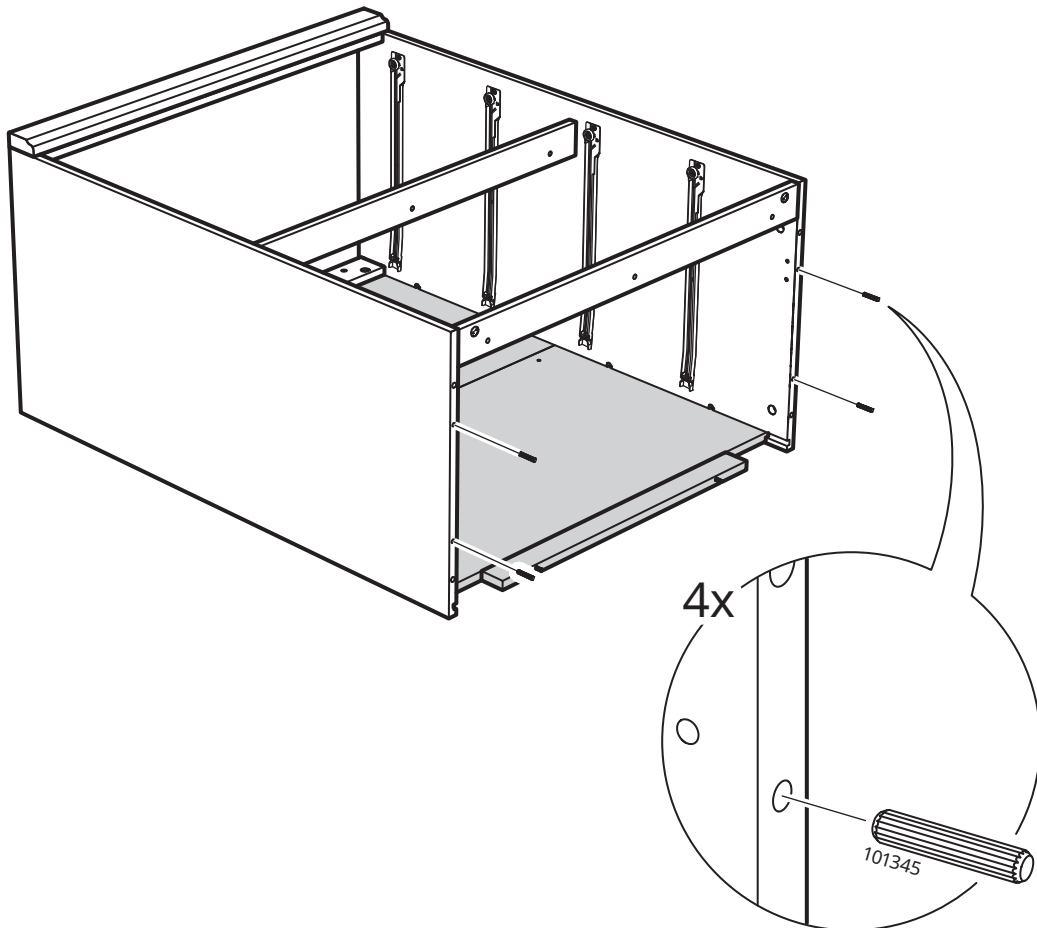

# 13

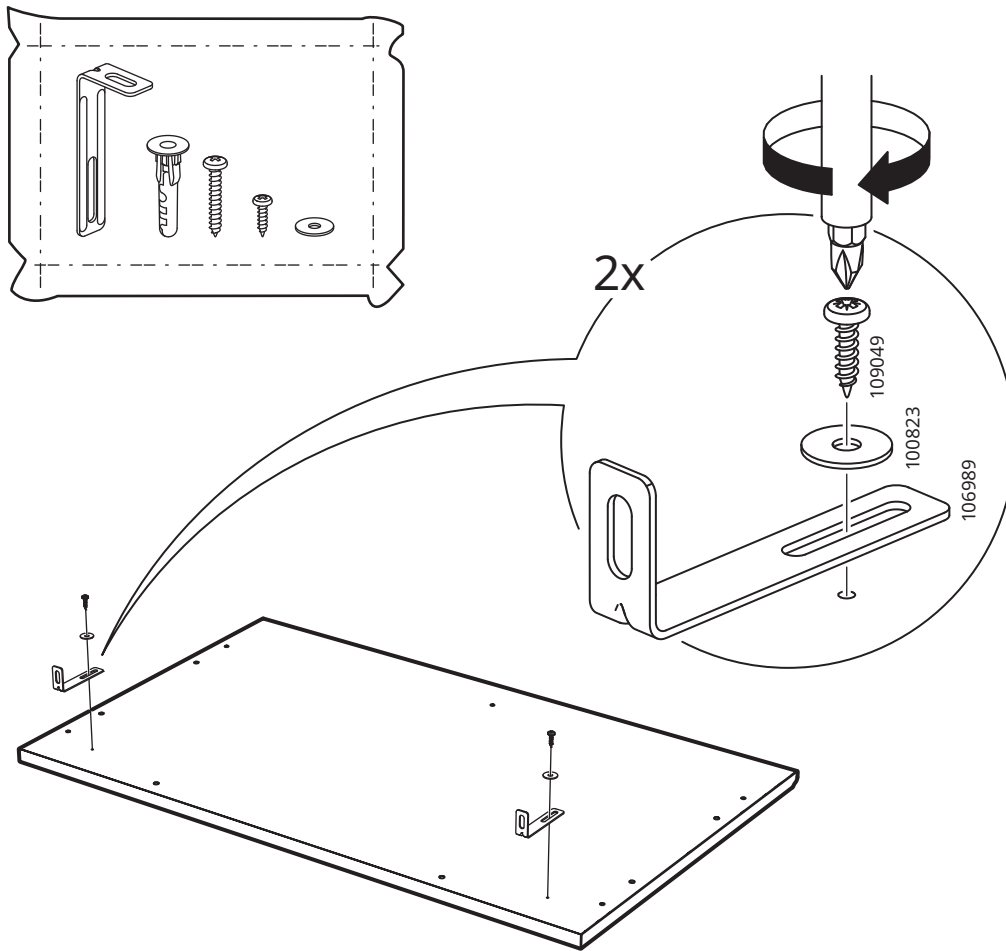

# 14

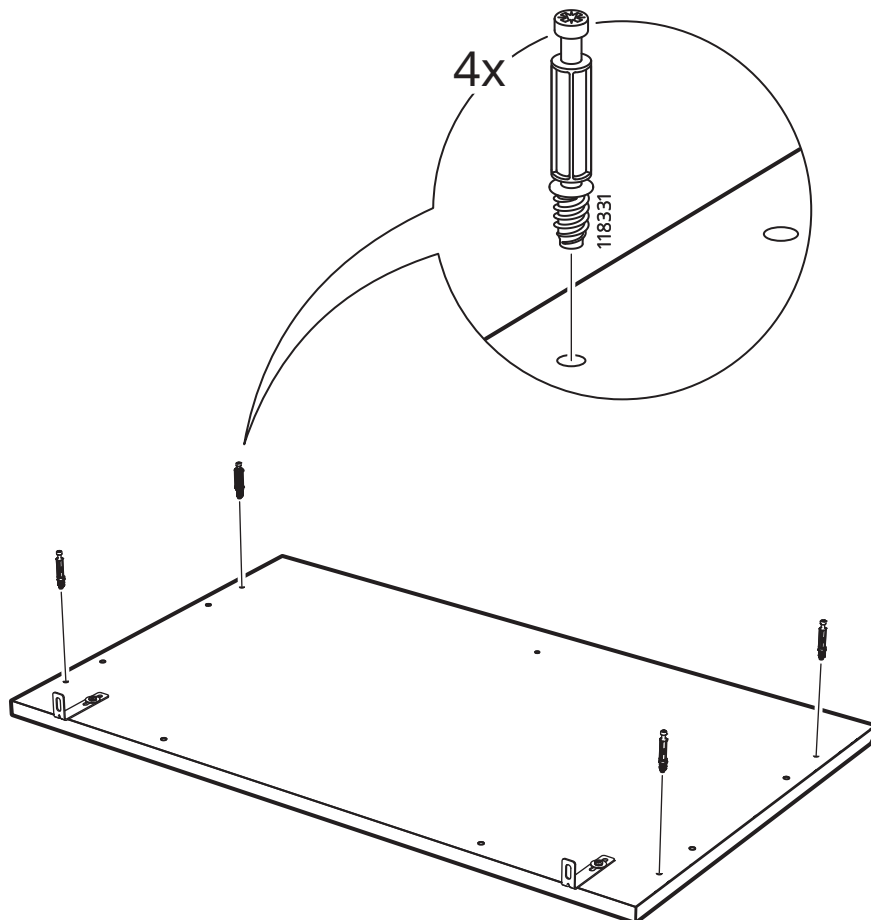

15

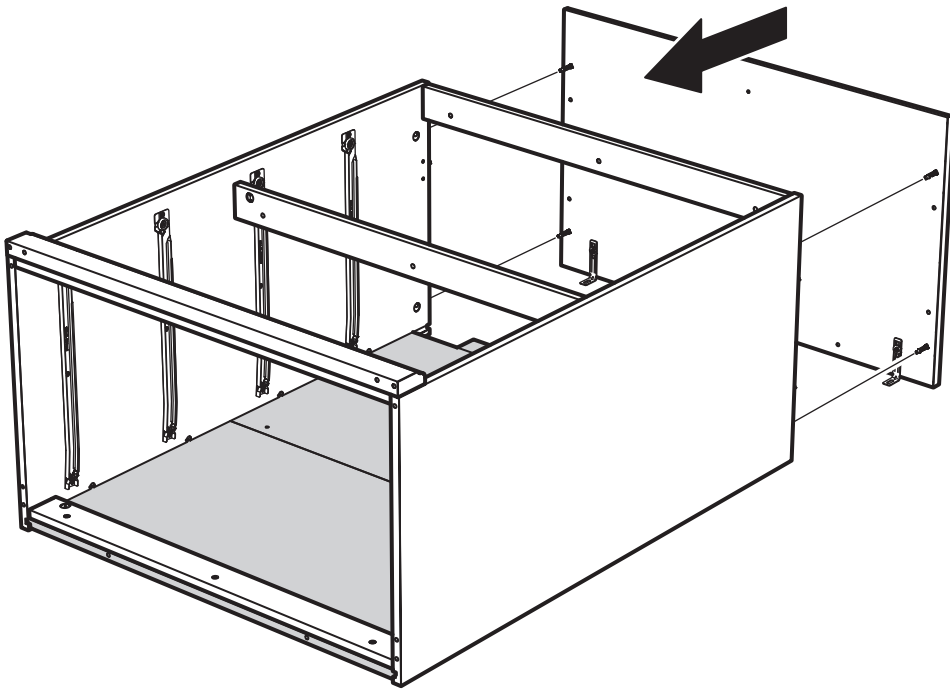

16

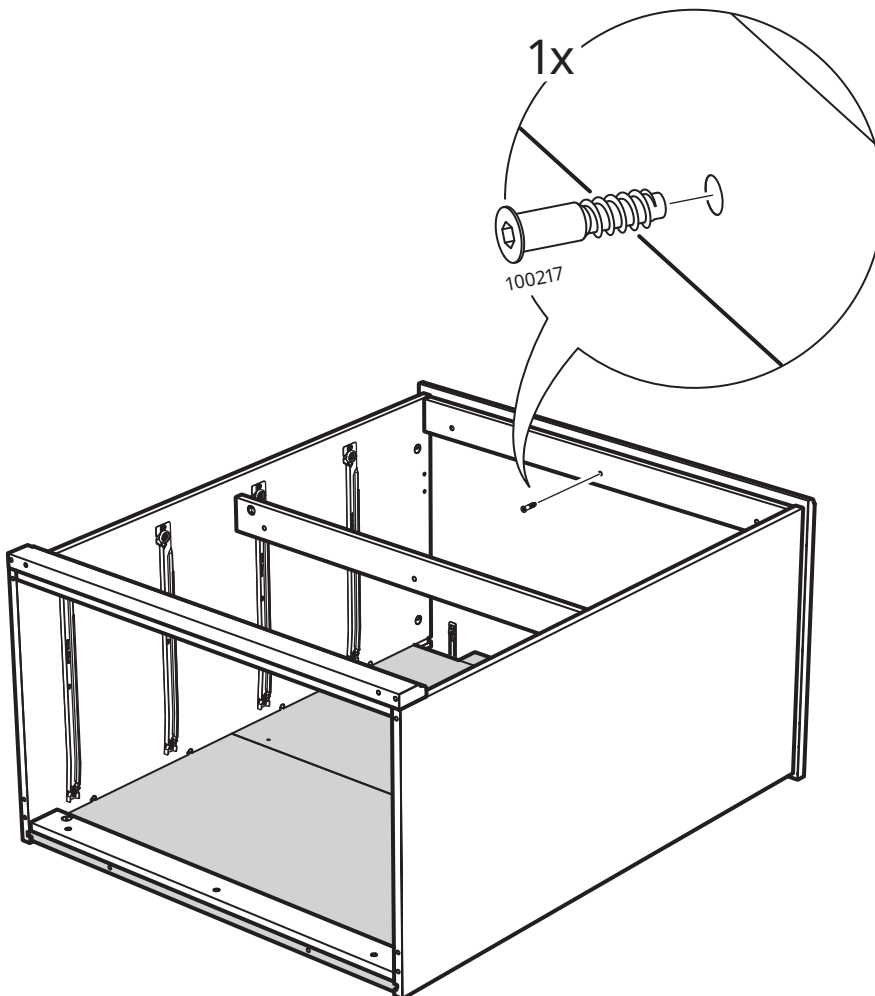

17

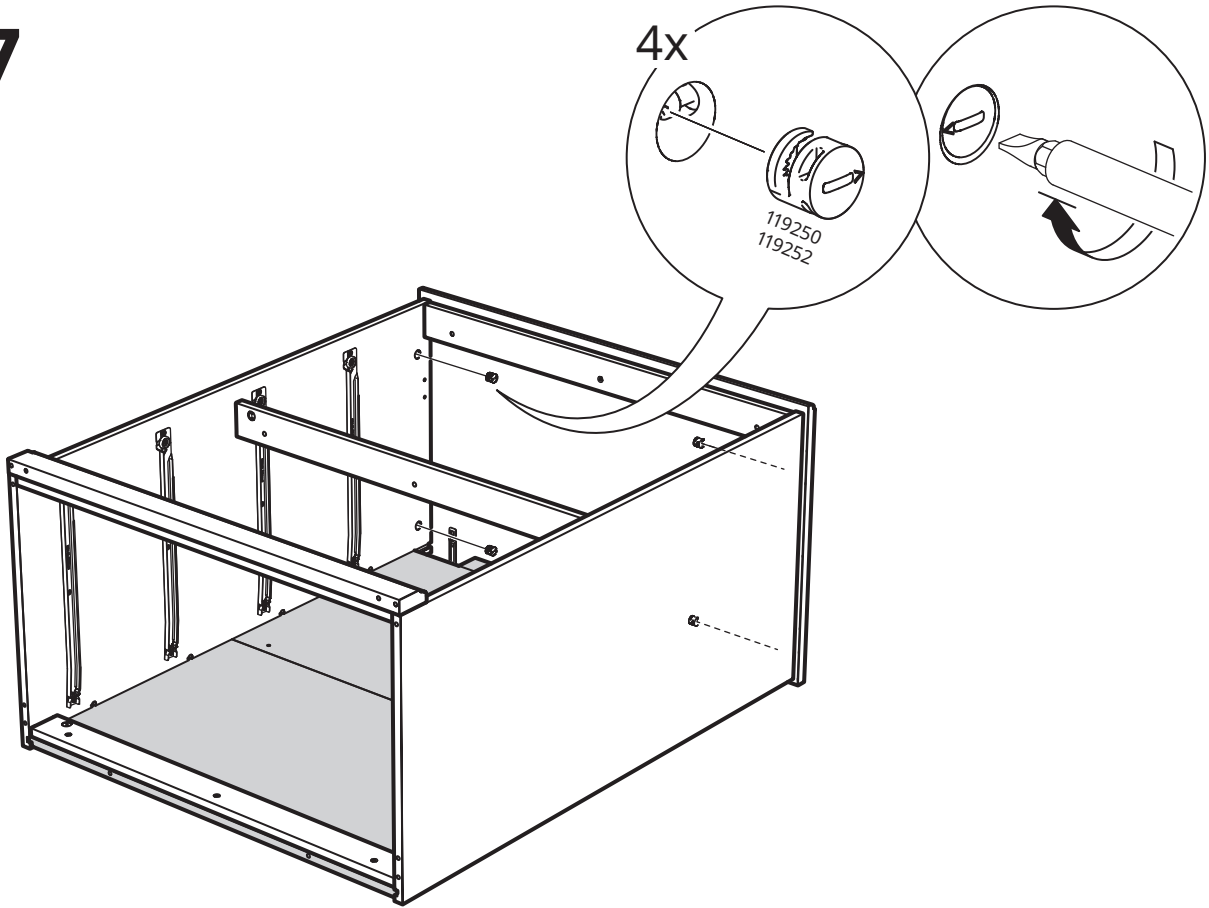

18

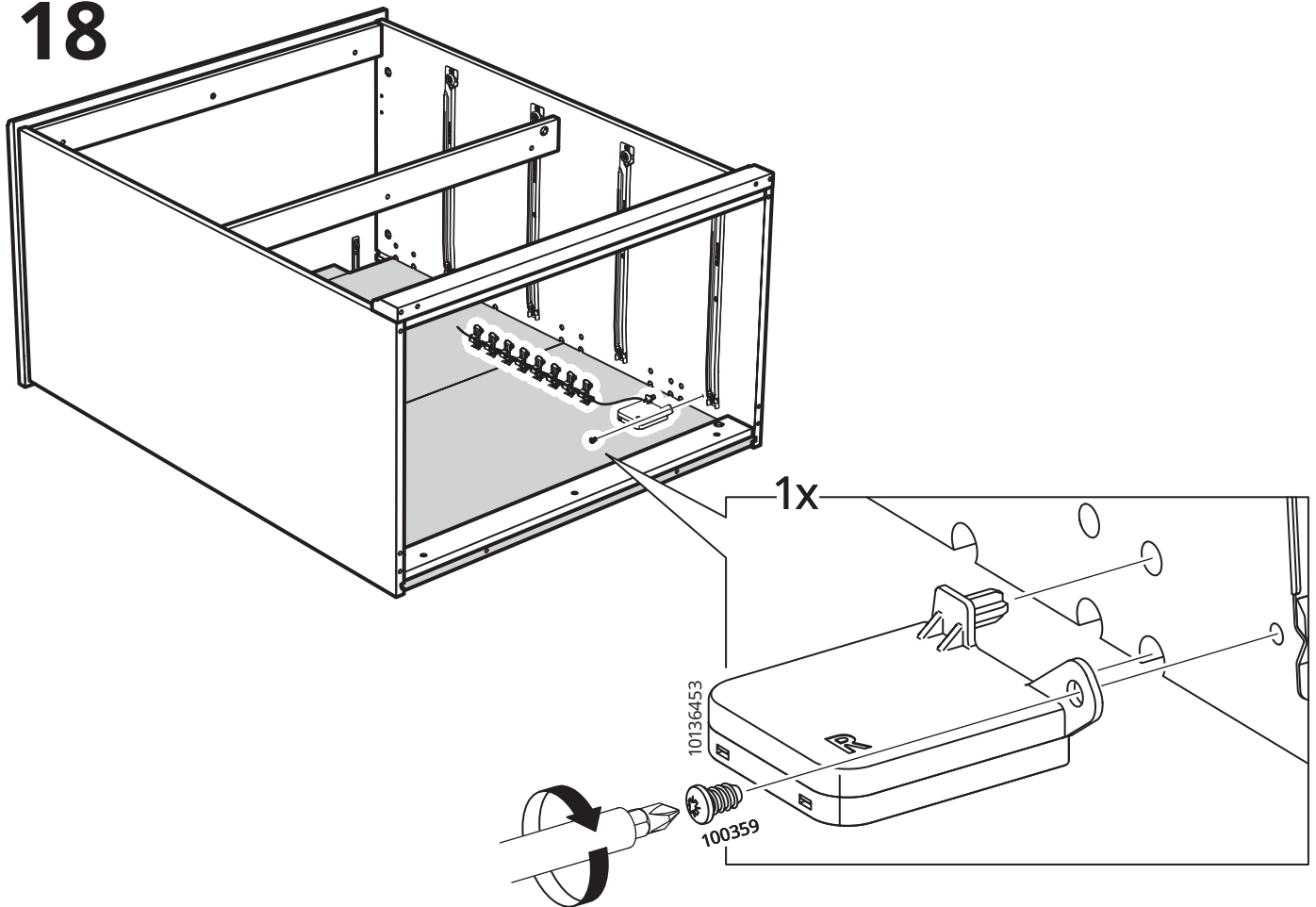

19

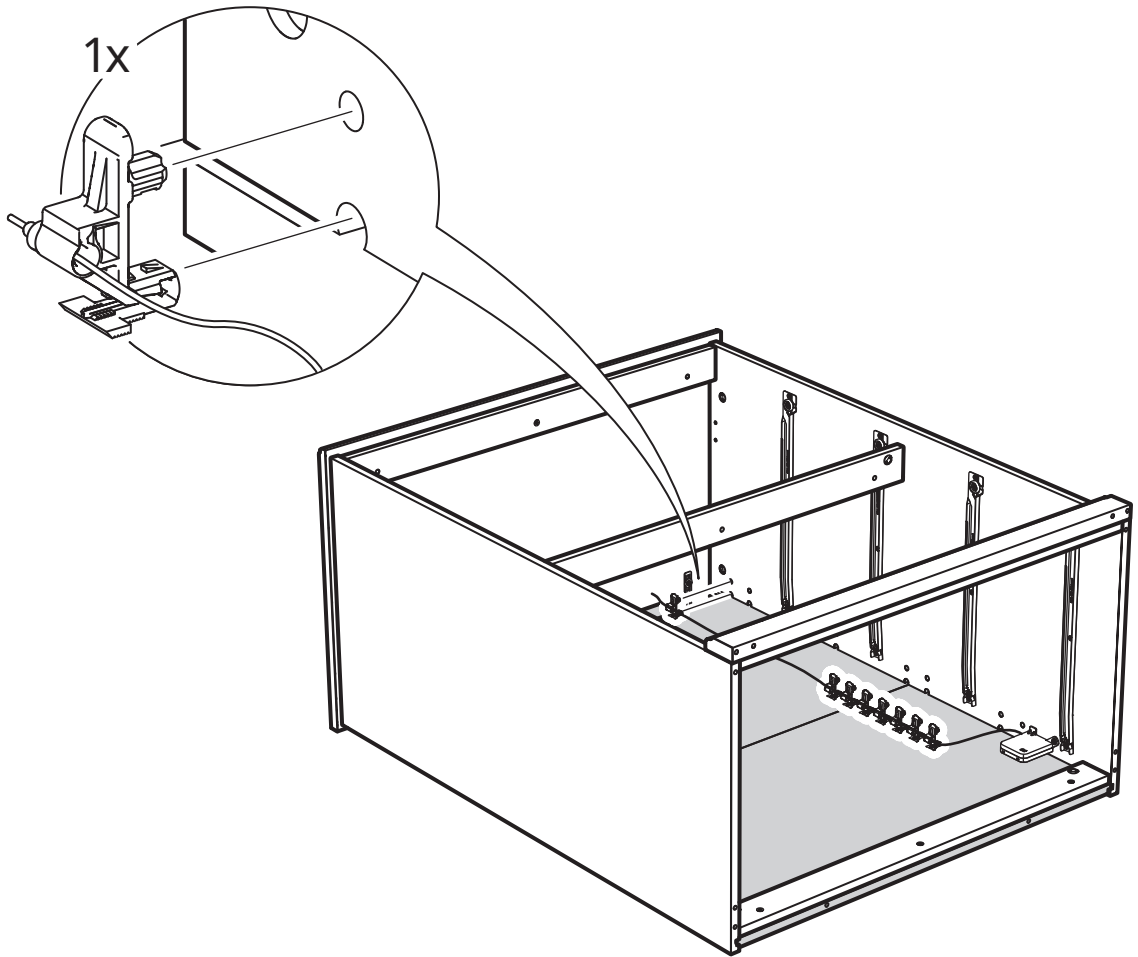

20

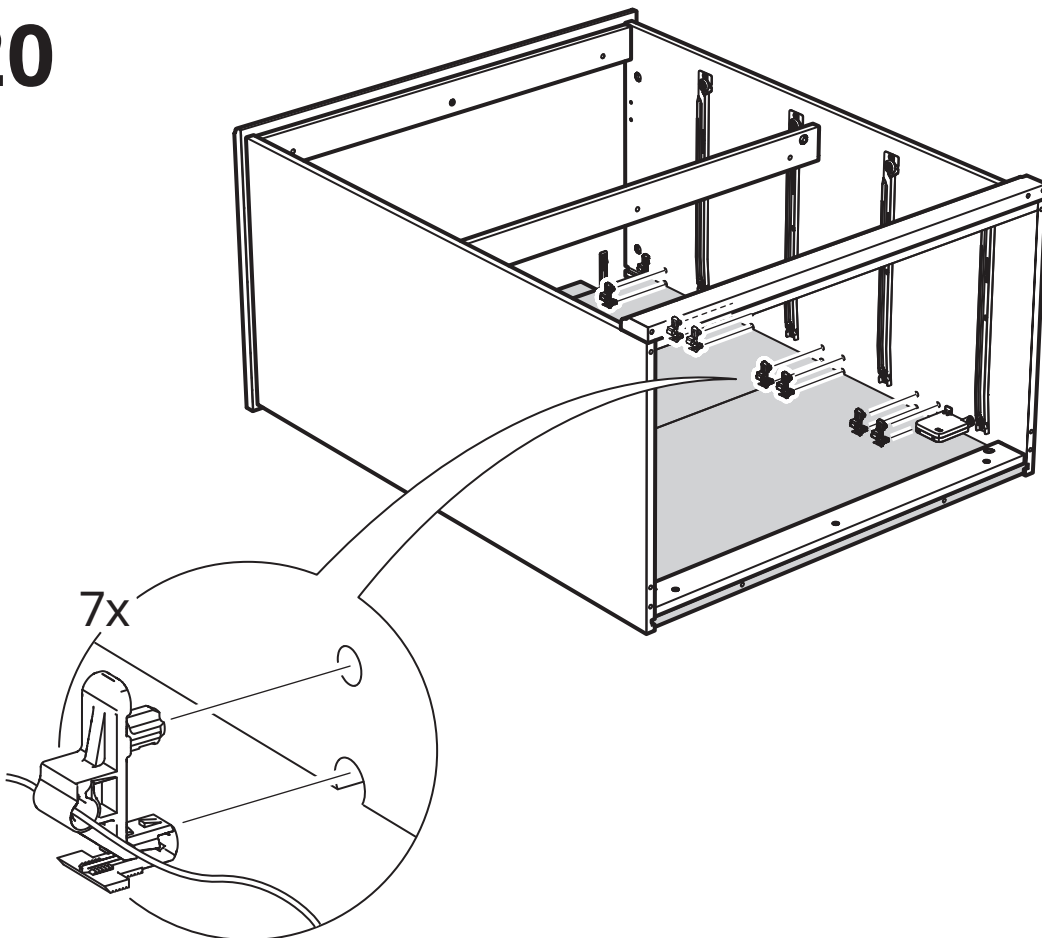

21

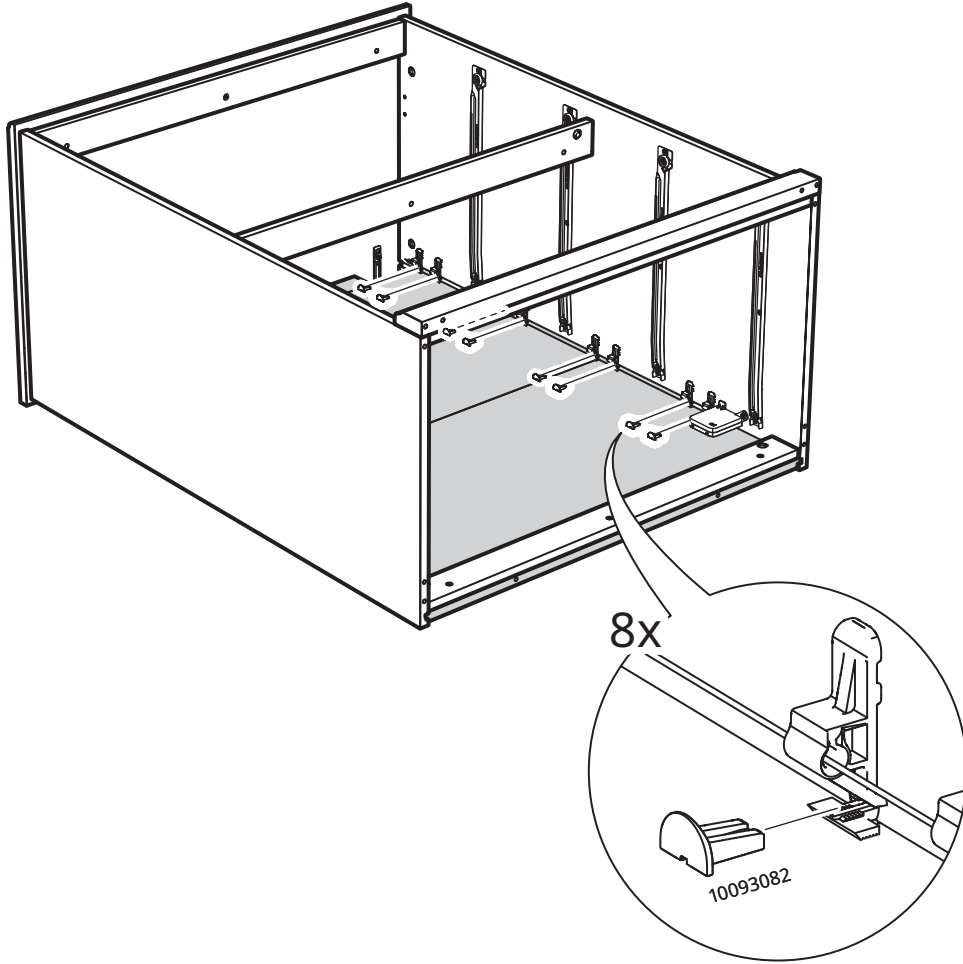

22

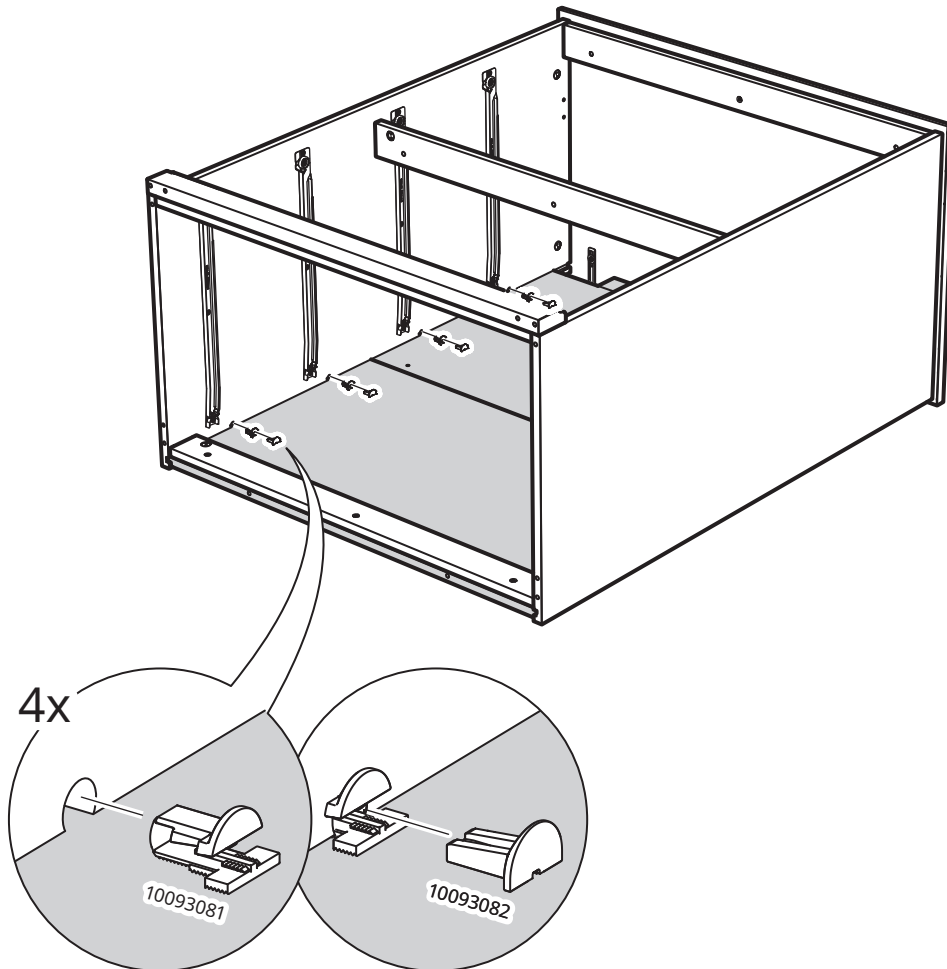

# 23

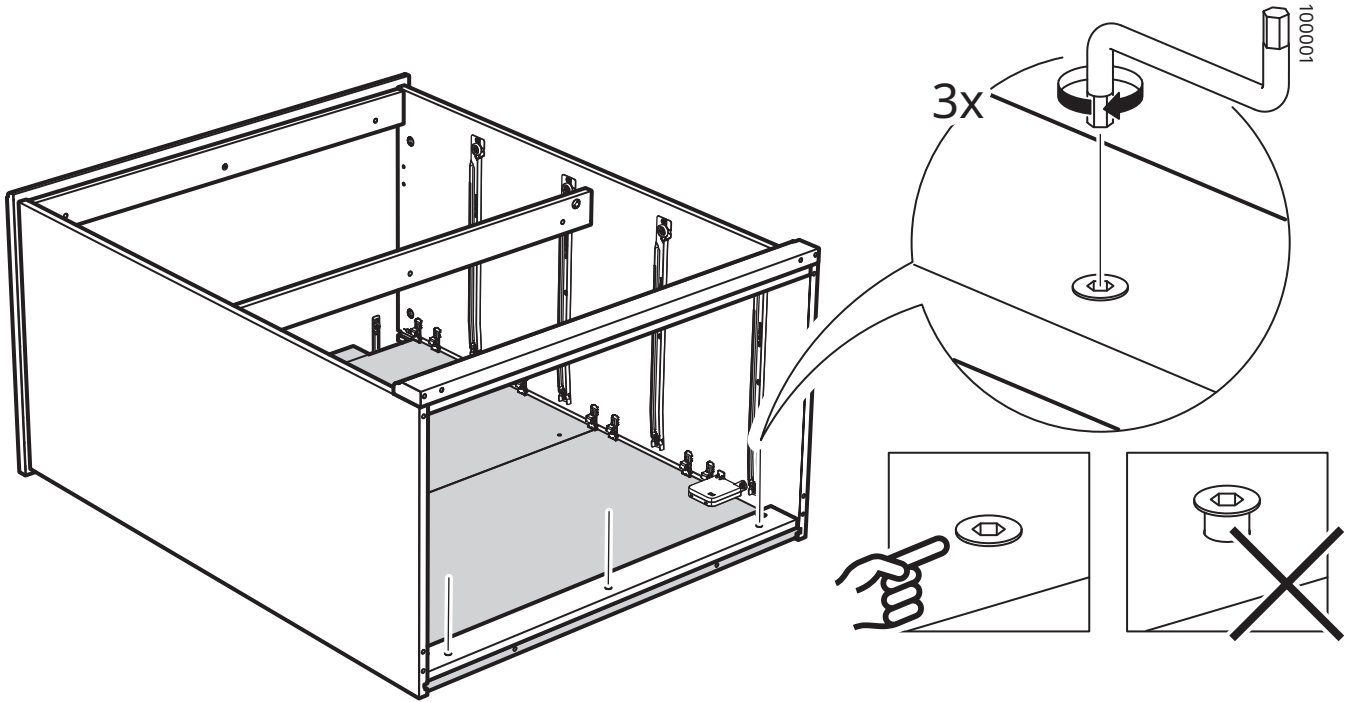

# 24

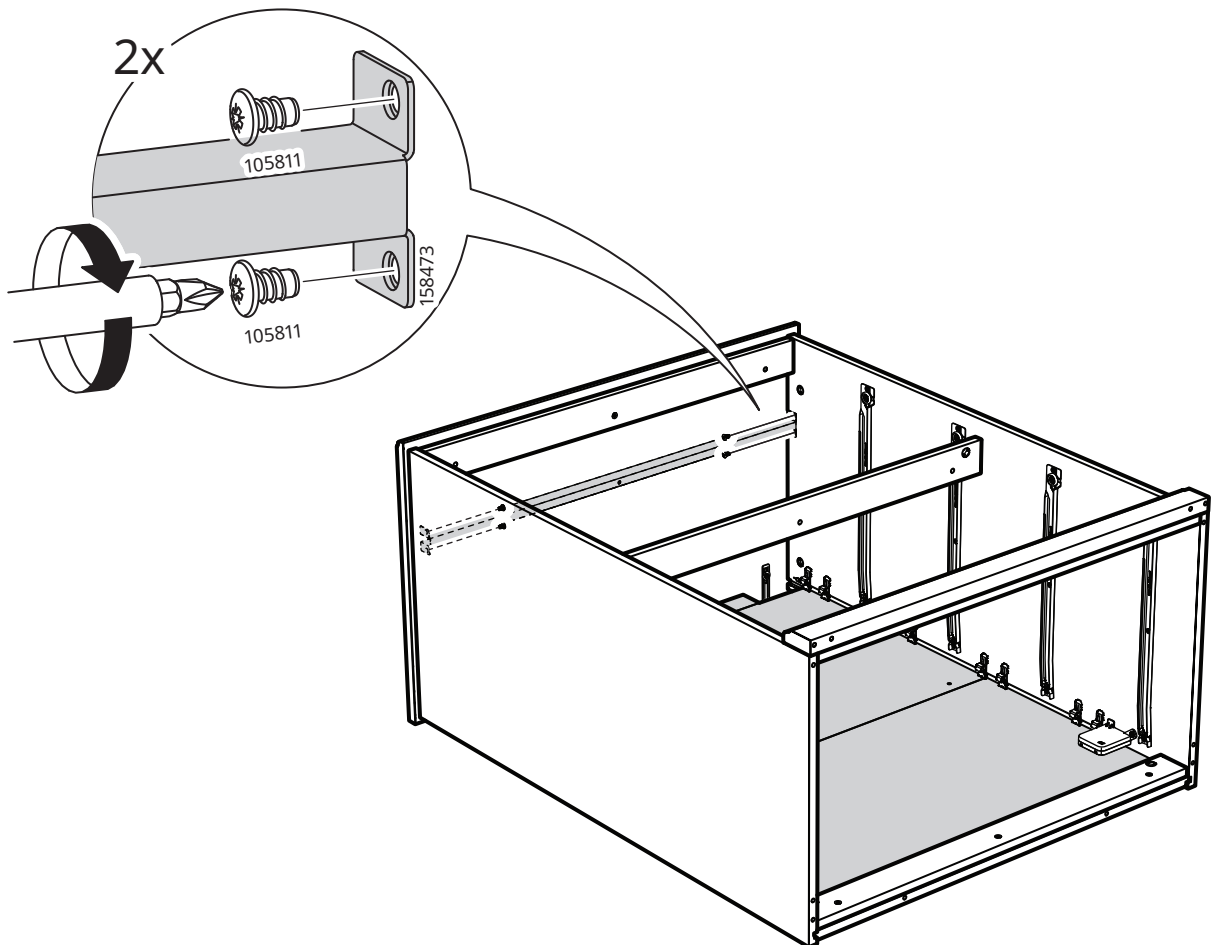

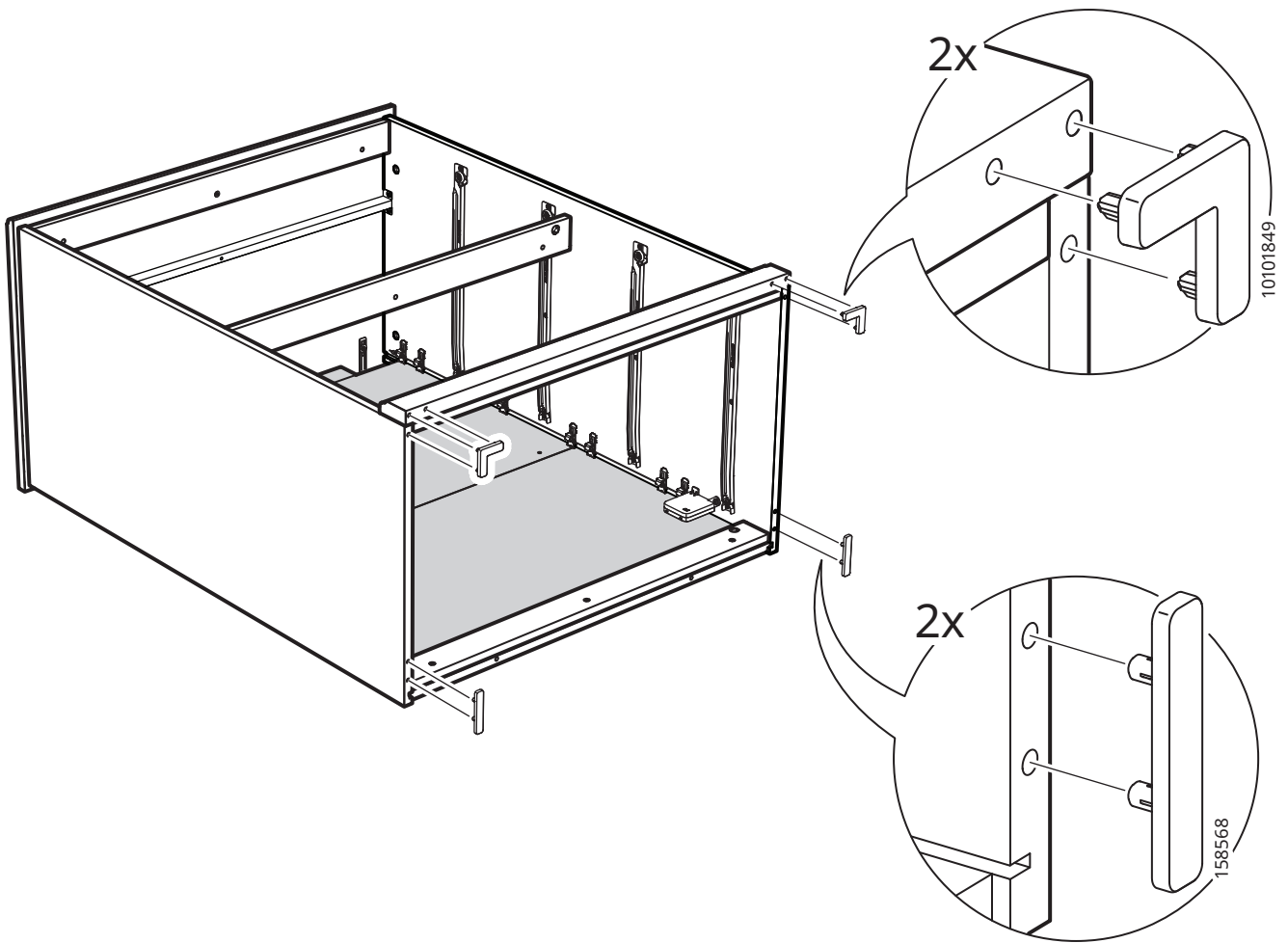

# 26

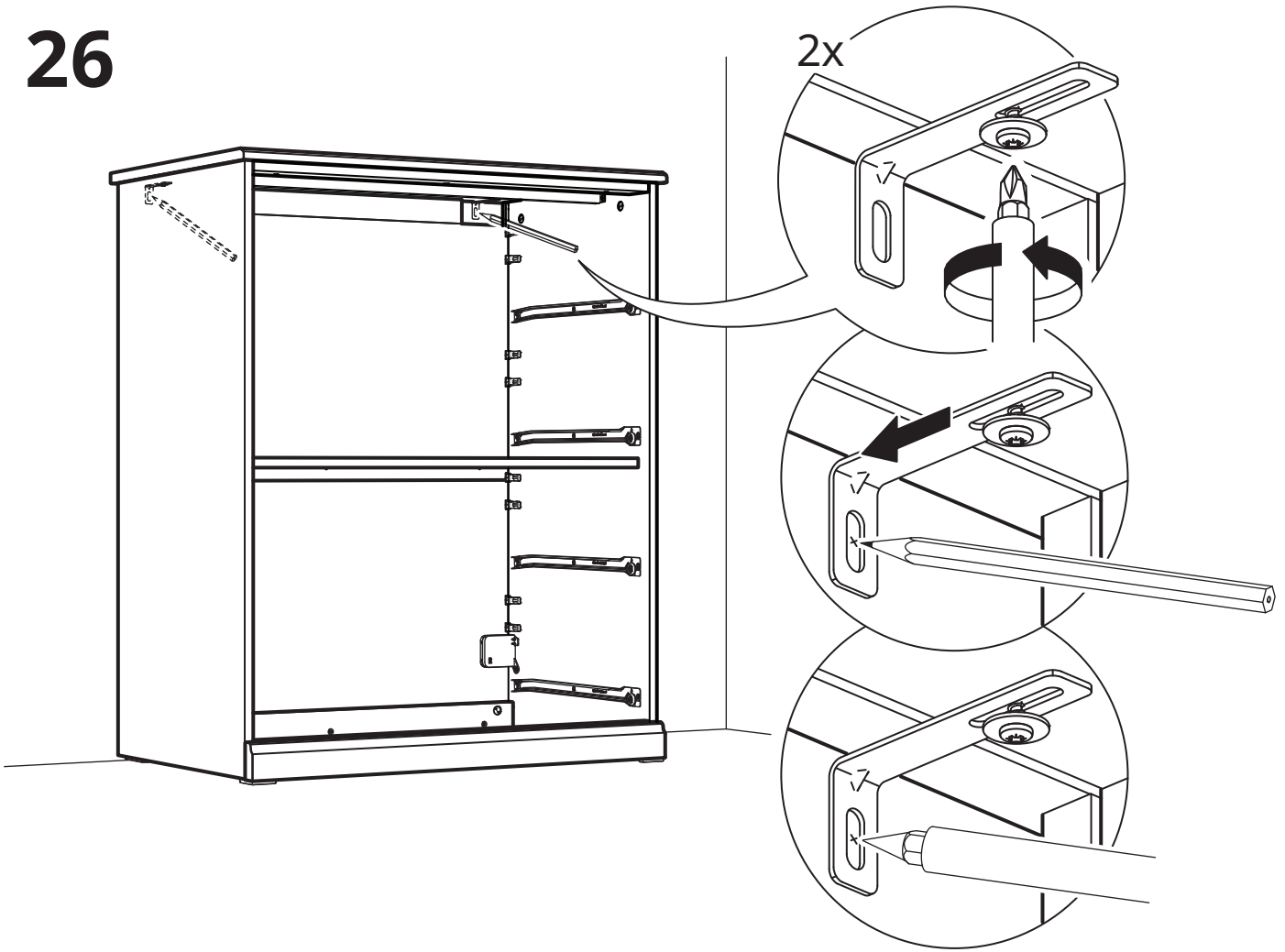

# 27

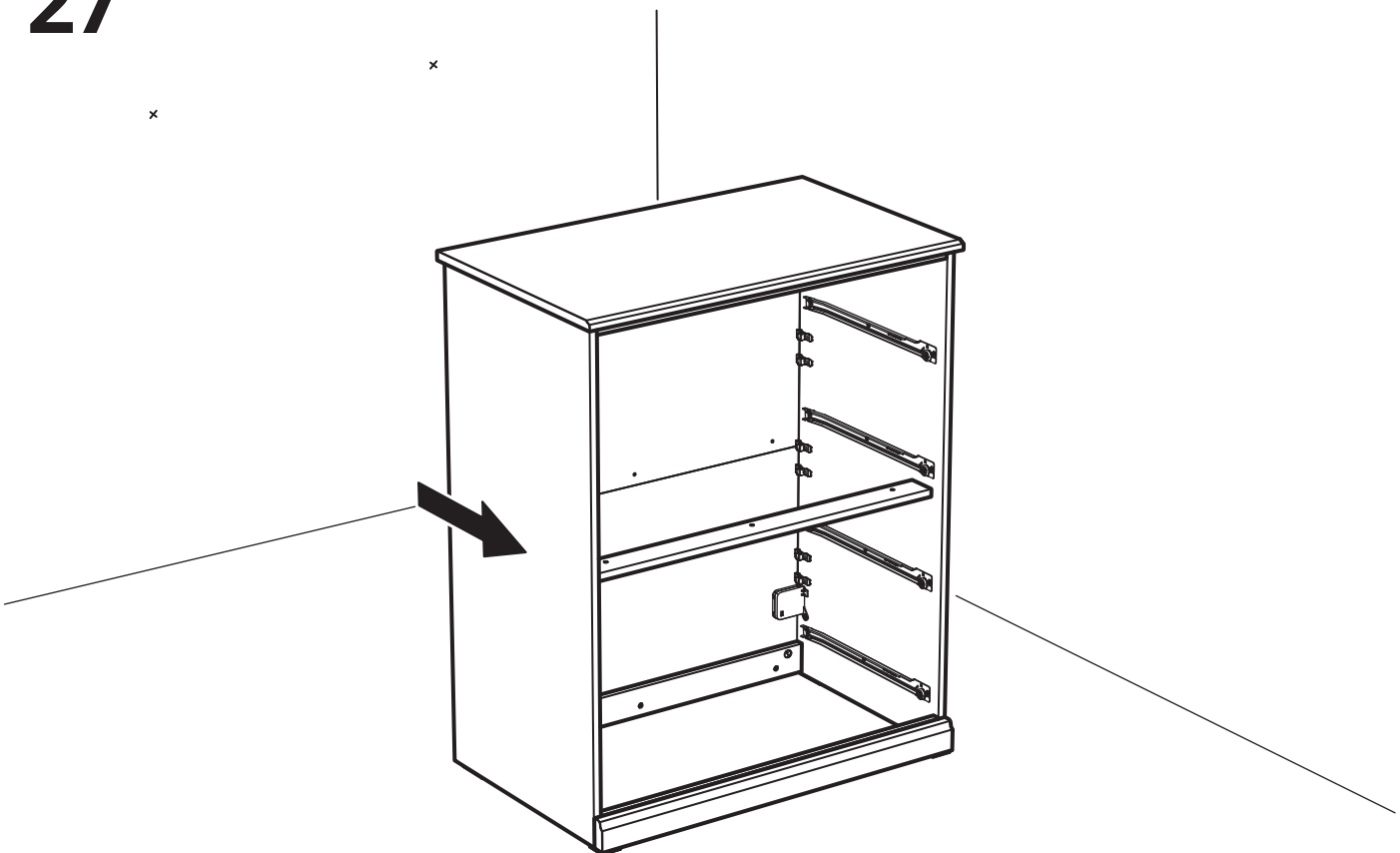



www.IKEA.com/secure-it



www.IKEA.cn/secure-it

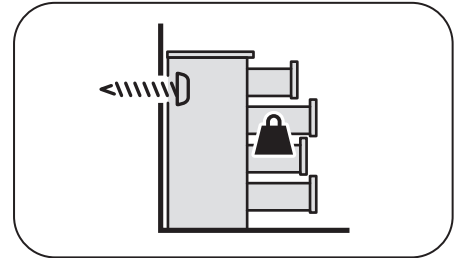

# 28

## English

The screw(s) and plug(s) supplied can be used with most solid (A) and hollow (B) walls. For solid wood (C) use the screw(s) without plug(s). If you are uncertain, seek professional advice.

## Español

Los tornillos y tacos incluidos se pueden utilizar en la mayor parte de las paredes sólidas (A) o huecas (B). Para la madera maciza (C), usa los tornillos sin tacos. Si tienes dudas, acude a un experto.

## Portugues

Os parafusos e os pinos fornecidos podem ser usados na maior parte das paredes maciças (A) e ocas (B). Para madeira maciça (C), use parafusos sem pinos. Se não tiver a certeza, peça ajuda a um técnico especializado.

## 中文

产品随附的螺丝和螺栓适用于大部分实心 (A) 和空心 (B) 墙壁。实木墙壁 (C) 只需要使用螺丝，不必搭配螺栓。如不确定适合的螺丝类型，请咨询专业人士。

## 繁體中文

產品附的螺絲和壁虎適用於大部分的實心(A)和空心(B)牆壁。實木牆壁(C)應使用螺絲，不需搭配壁虎。如果不確定適合的螺絲類型，請洽詢服務人員。

## 한국어

제공된 나사와 플러그는 대부분의 단단한 벽(A)이나 중공벽(B)에 사용할 수 있습니다. 원목(C)에는 플러그없이 나사만 사용하세요. 반드시 전문가의 조언을 구하고 설치하세요.

**A**

Ø 8 mm (5/16")

**1**

70 mm (2 3/4")

**2**

24

**B**

Ø 8 mm (5/16")

**1**

≈ 30 mm (≈ 1 1/4")

**2**

25

**C**

Ø 3 mm (1/8")

**1**

≈ 30 mm (≈ 1 1/4")

27

## 日本語

付属のネジとプラグはほとんどの1枚壁 (A) や中空壁 (B) に使用できます。無垢材 (C) にはプラグなしネジをお使いください。取り付けに適したネジに関しては、専門店にご相談ください。

## Bahasa Indonesia

Sekrup dan plug yang disediakan dapat digunakan dengan sebagian besar dinding padat (A) dan berlubang (B). Untuk kayu solid (C) gunakan sekrup tanpa plug. Jika Anda tidak yakin, cari saran profesional.

## Bahasa Malaysia

Skru dan palam yang dibekalkan boleh digunakan pada kebanyakan dinding padu (A) dan berongga (B). Untuk kayu padu (C) gunakan skru tanpa palam. Jika anda kurang pasti, dapatkan nasihat profesional.

## عربي

يمكن استخدام المسامير (المسامير) والحشوة (الحشوات) البلاستيكية المرفقة في معظم الجدران الصلبة (A) والمجووفة (B). أما مع الخشب الصلب (C)، استخدم المسامير (المسامير) بدون حشوات. في حالة عدم المعرفة، يرجى طلب مساعدة فني مختص.

## ไทย

สกรูและพุกที่ให้มาสามารถใช้กับผนังที่แข็ง (A) และกลวง (B) ได้เป็นส่วนใหญ่ สำหรับผนังไม้แท้ (C) ให้ใช้เฉพาะสกรู โดยไม่ต้องใช้พุก หากไม่แน่ใจเรื่อง การเลือกและใช้วัสดุยึดผนัง ควรสอบถามผู้เชี่ยวชาญ

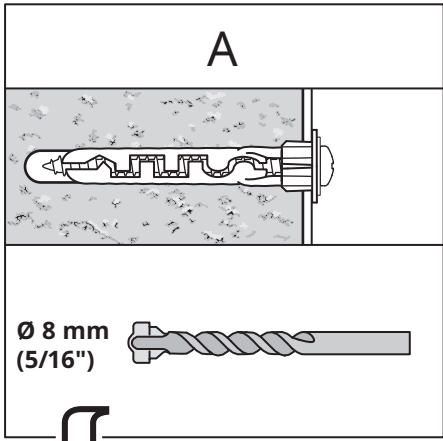

**29**

x

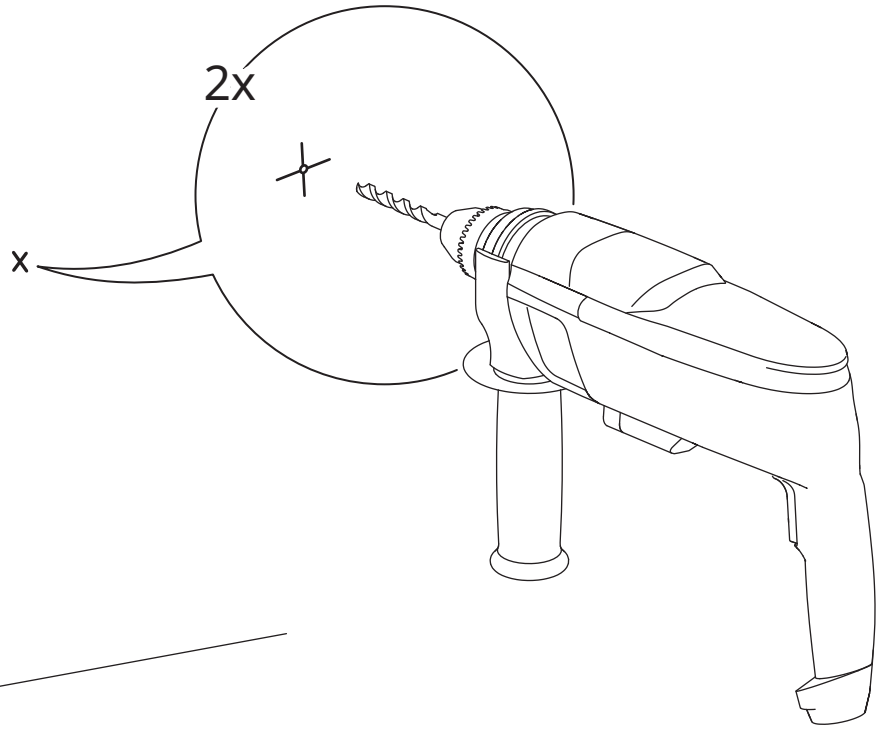

**30**

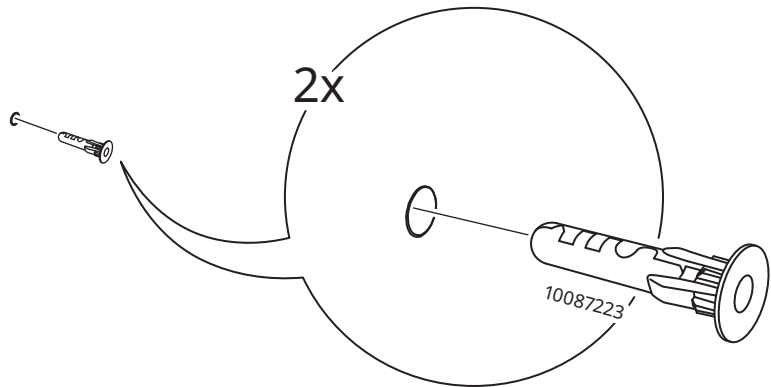

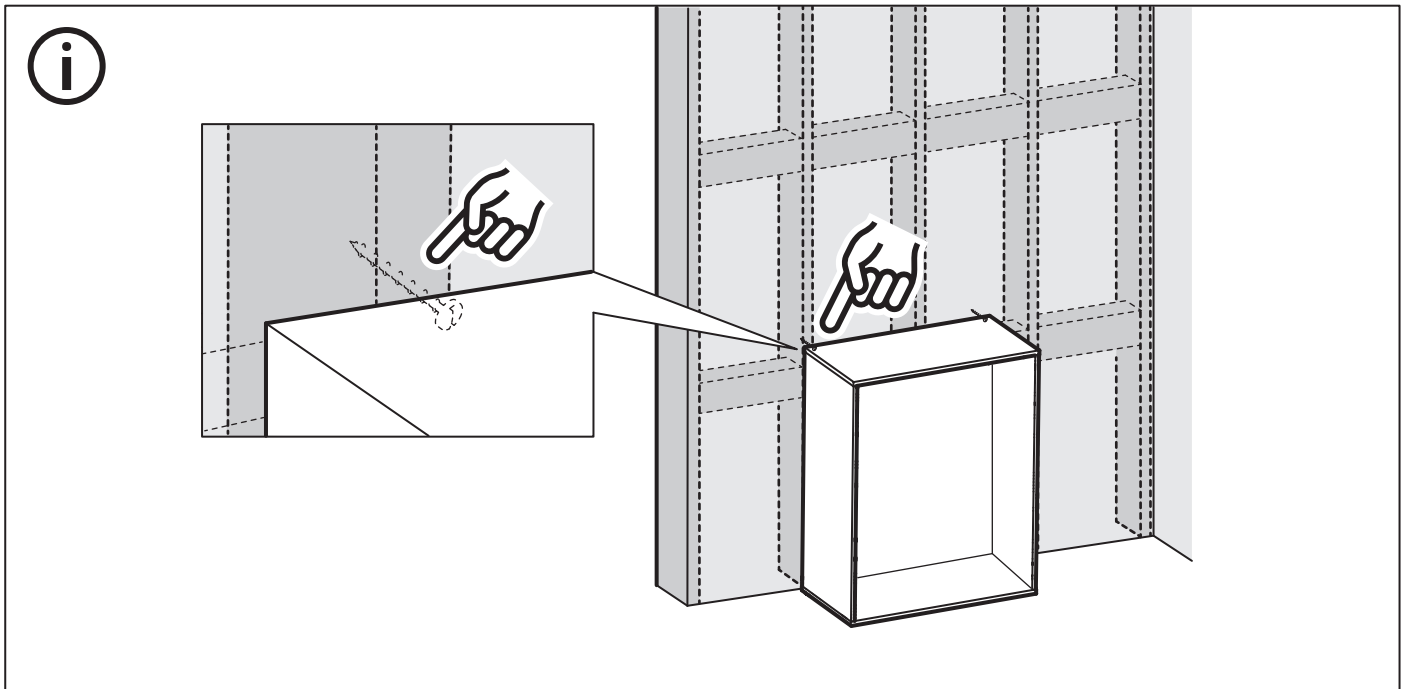
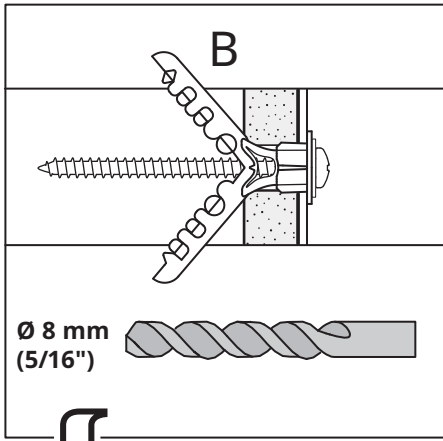

29

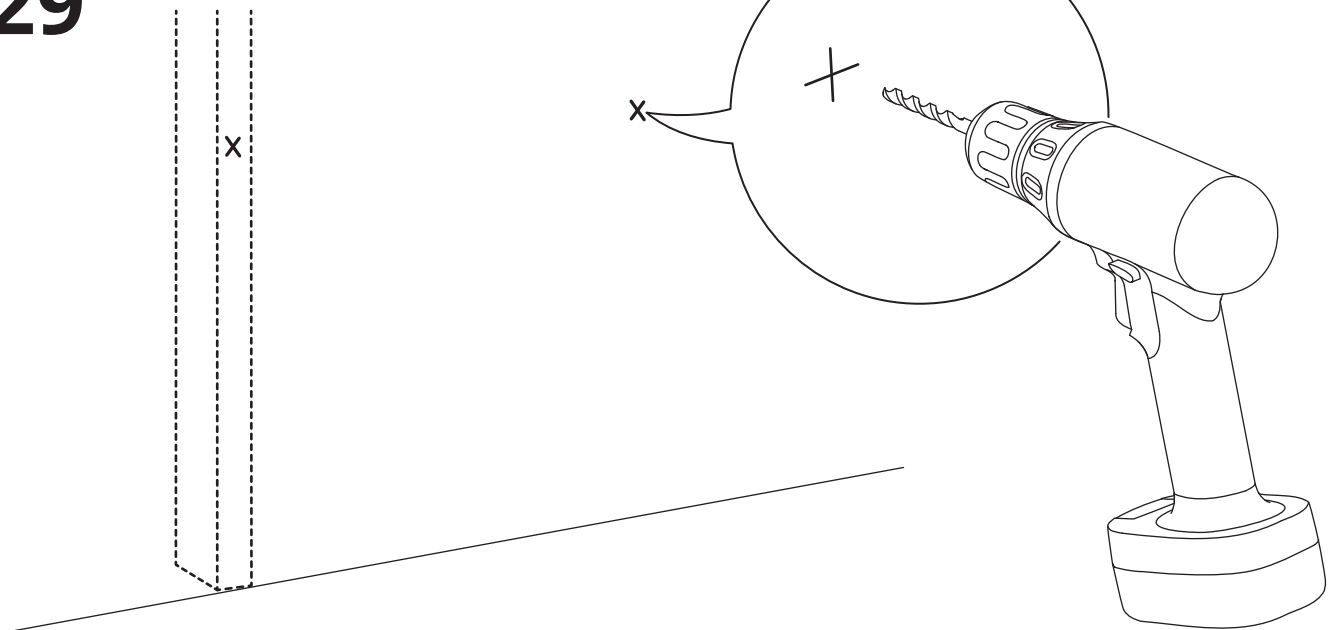

30

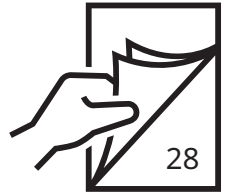
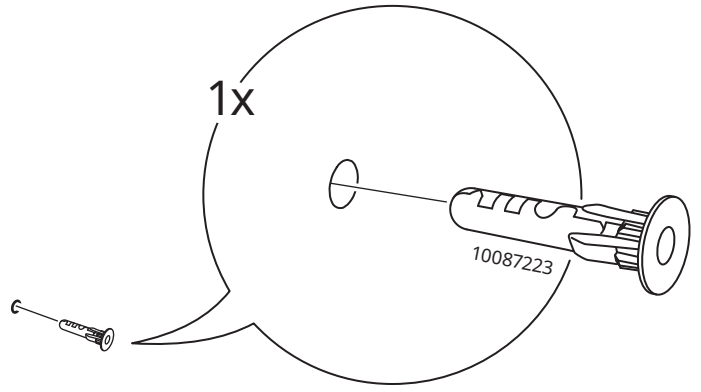
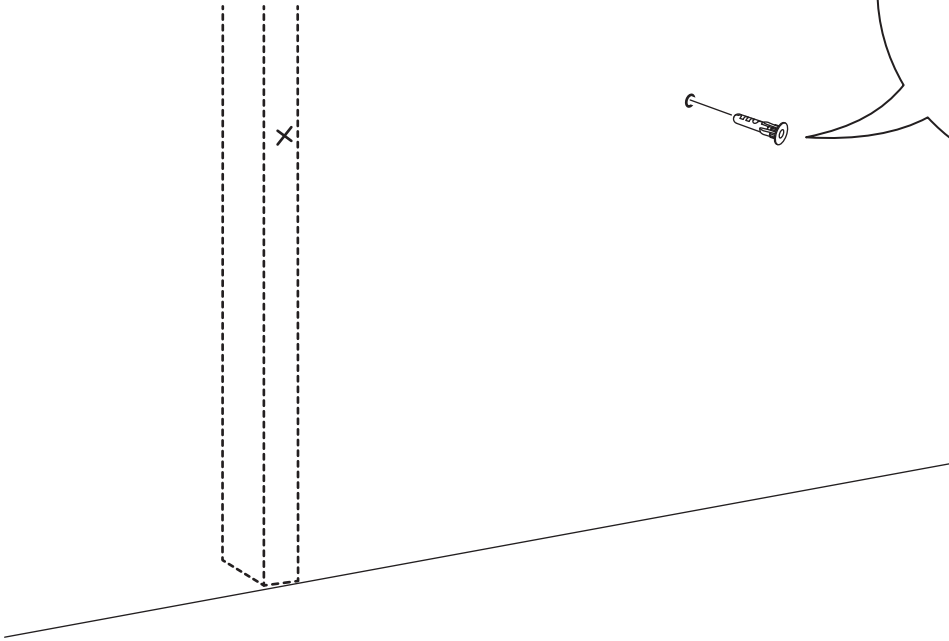

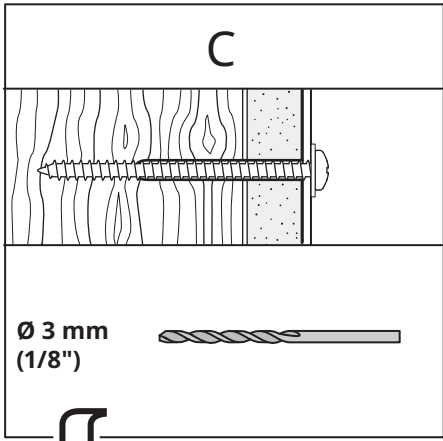

29

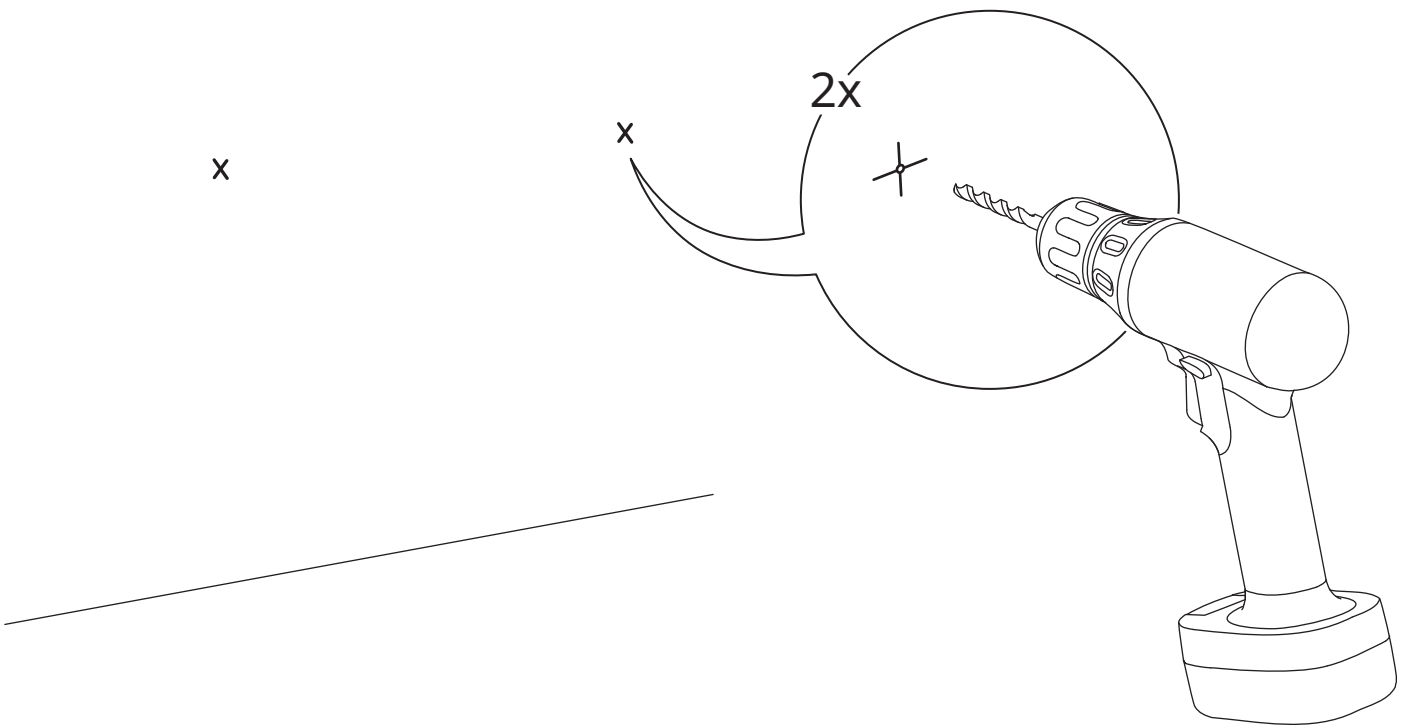

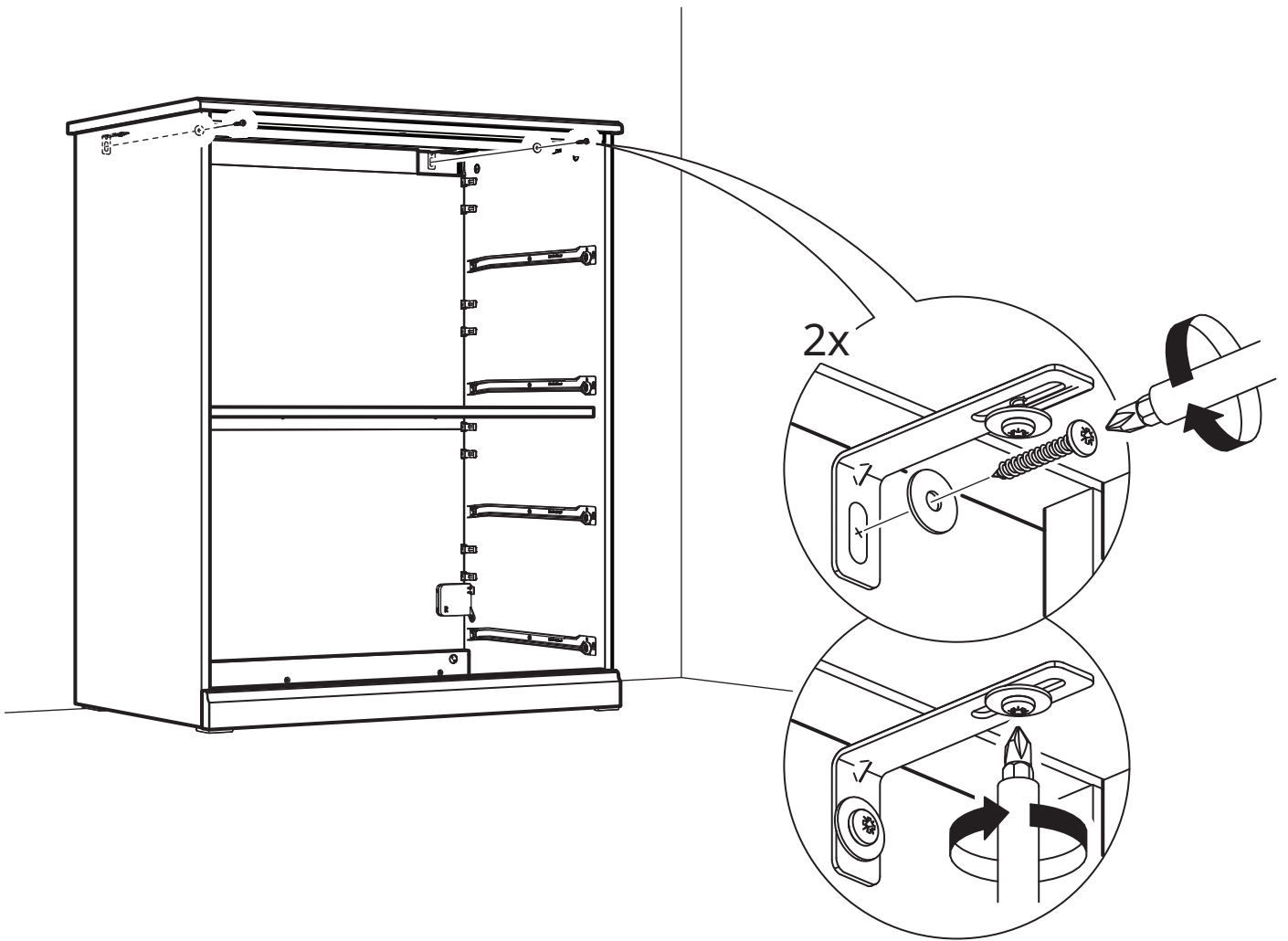

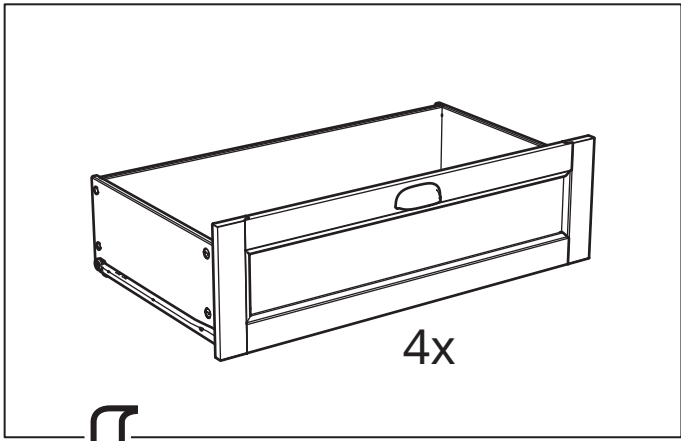

32

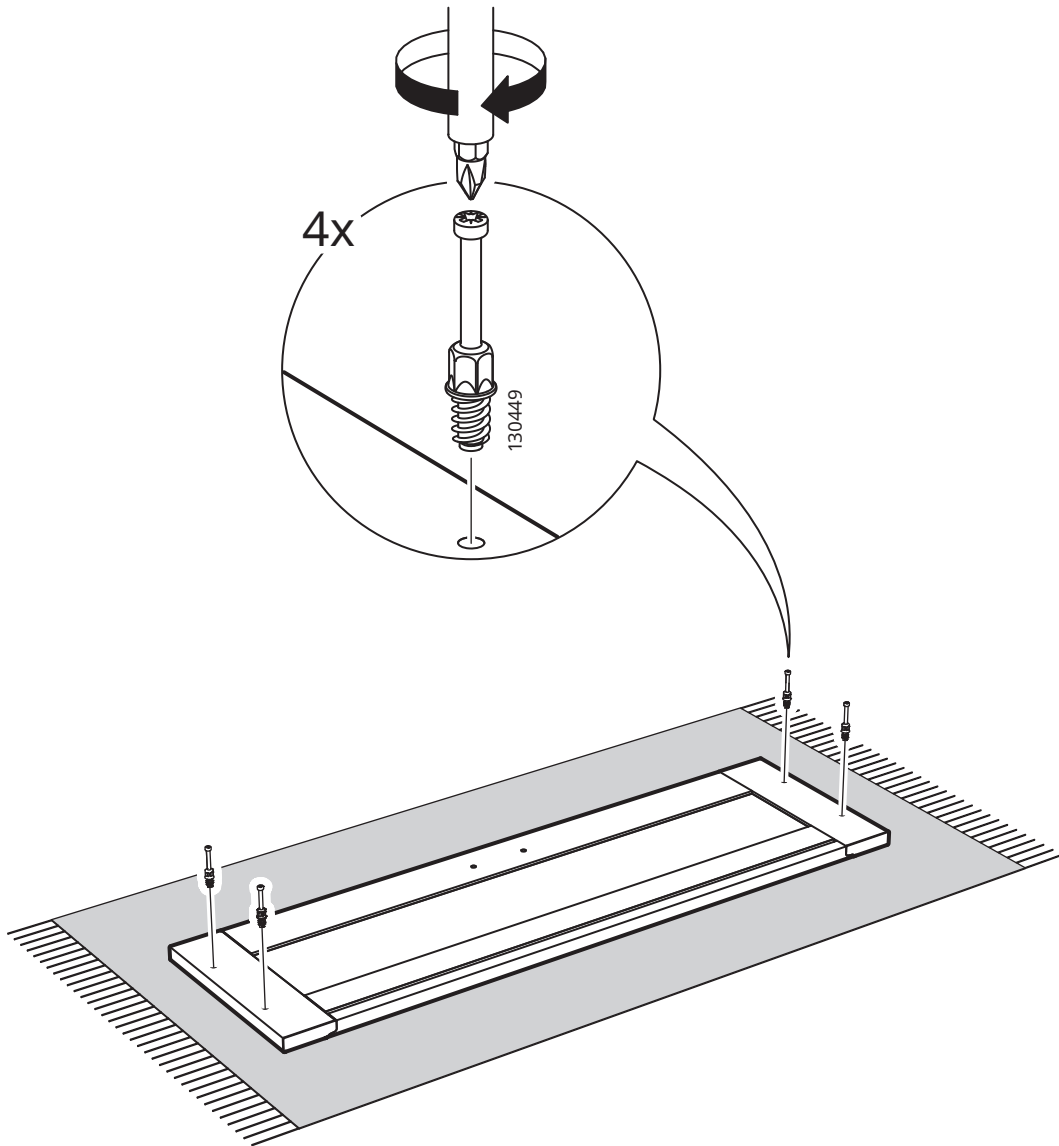

# 33

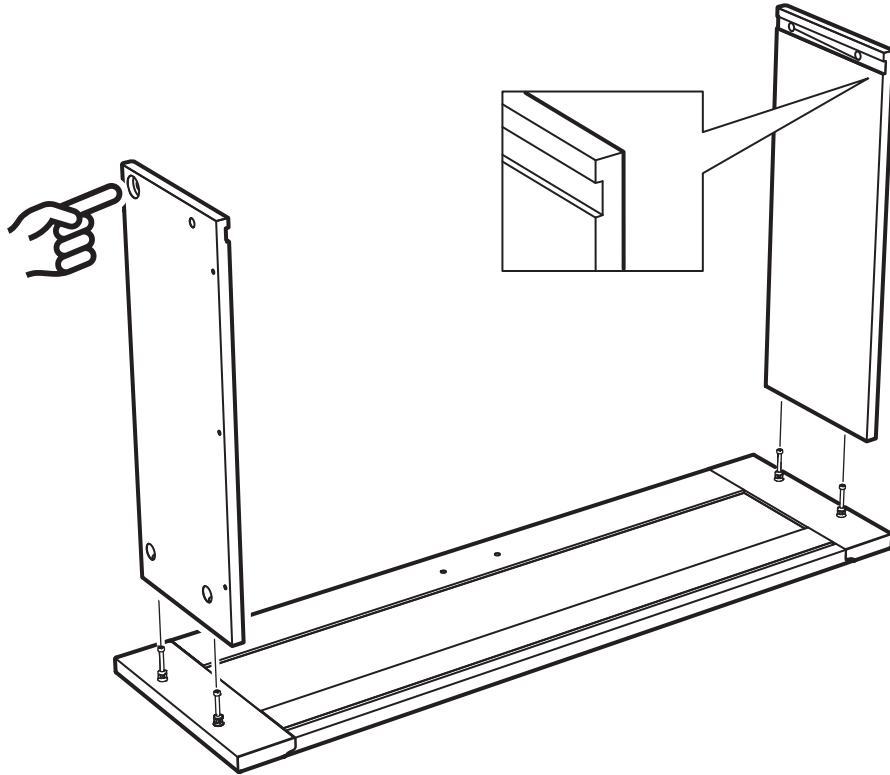

# 34

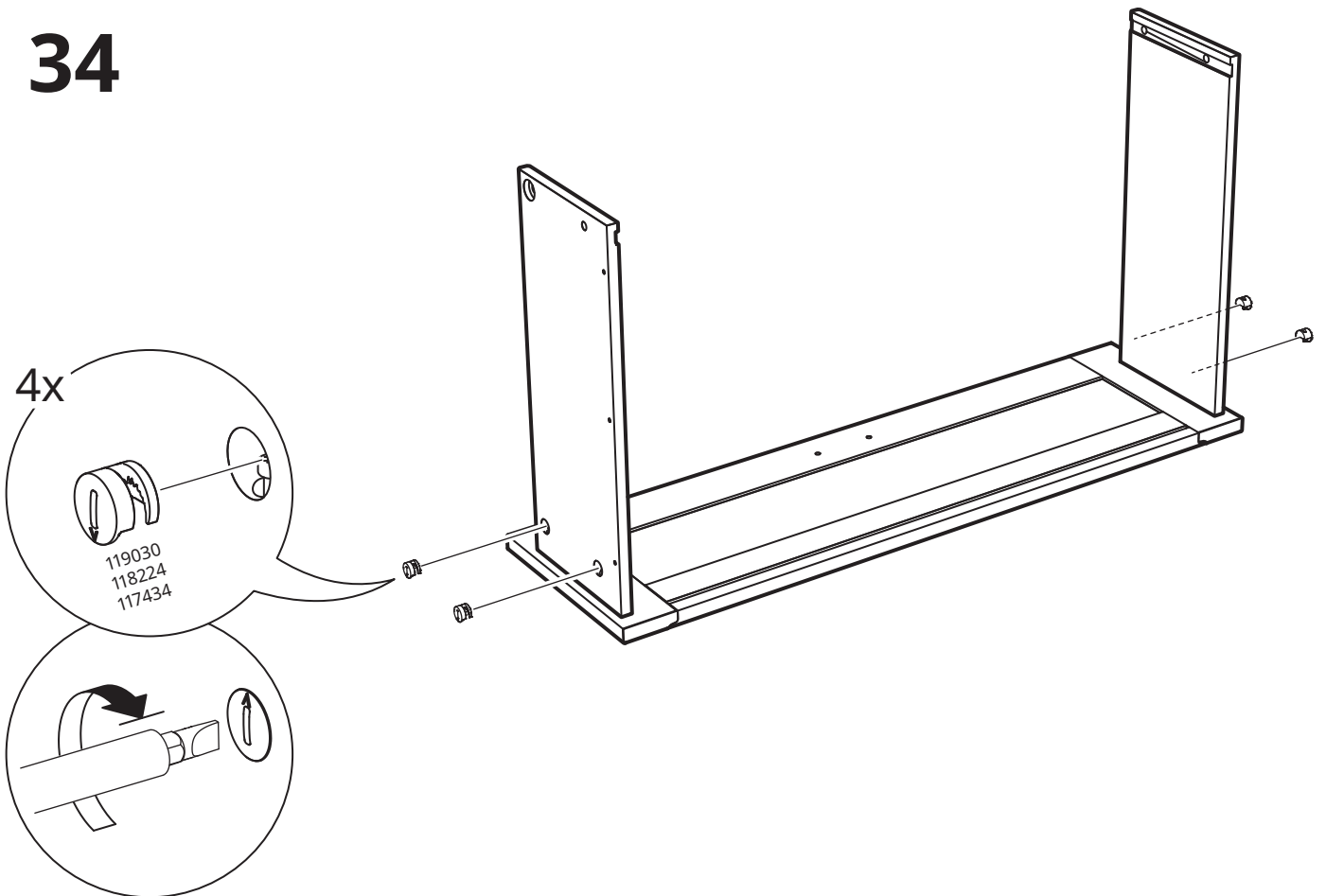

# 35

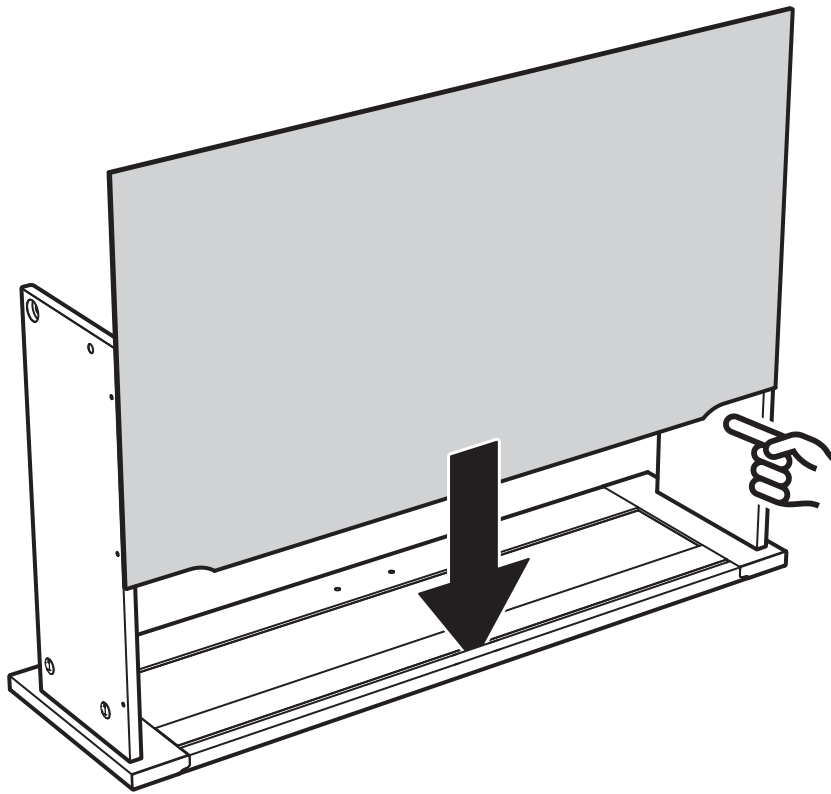

# 36

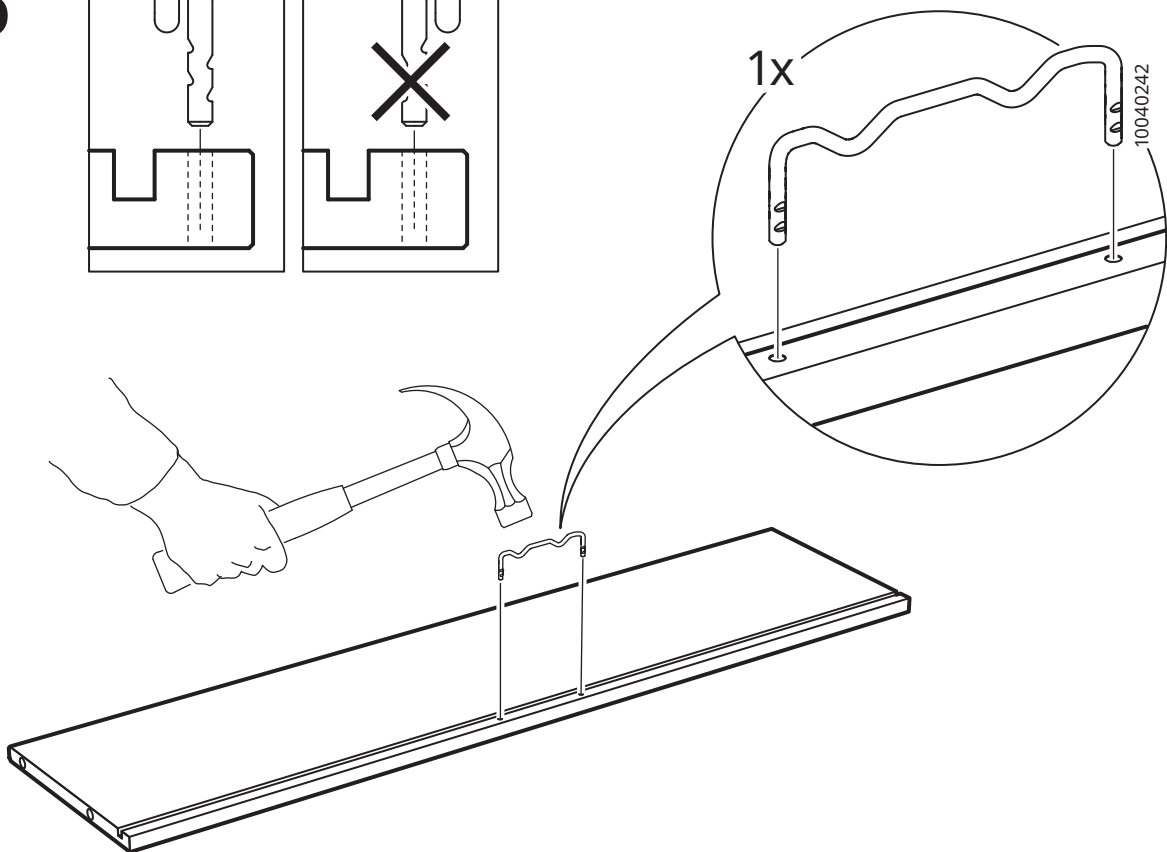
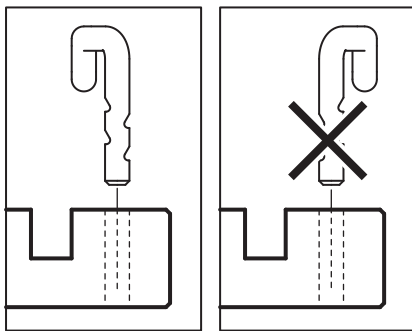

# 37

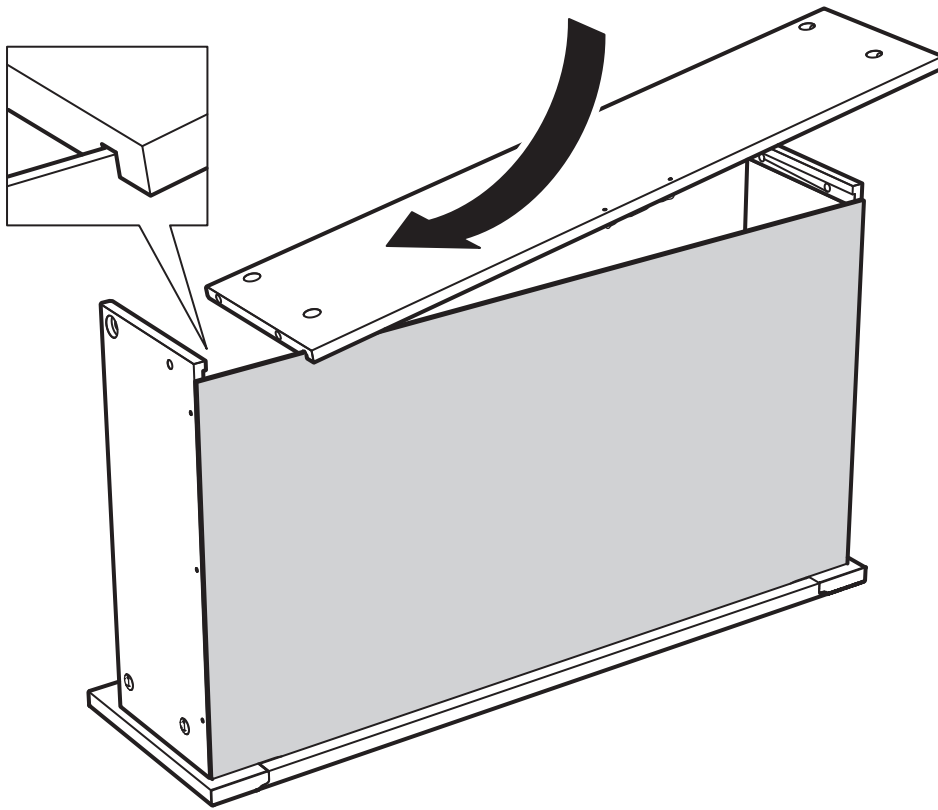

# 38

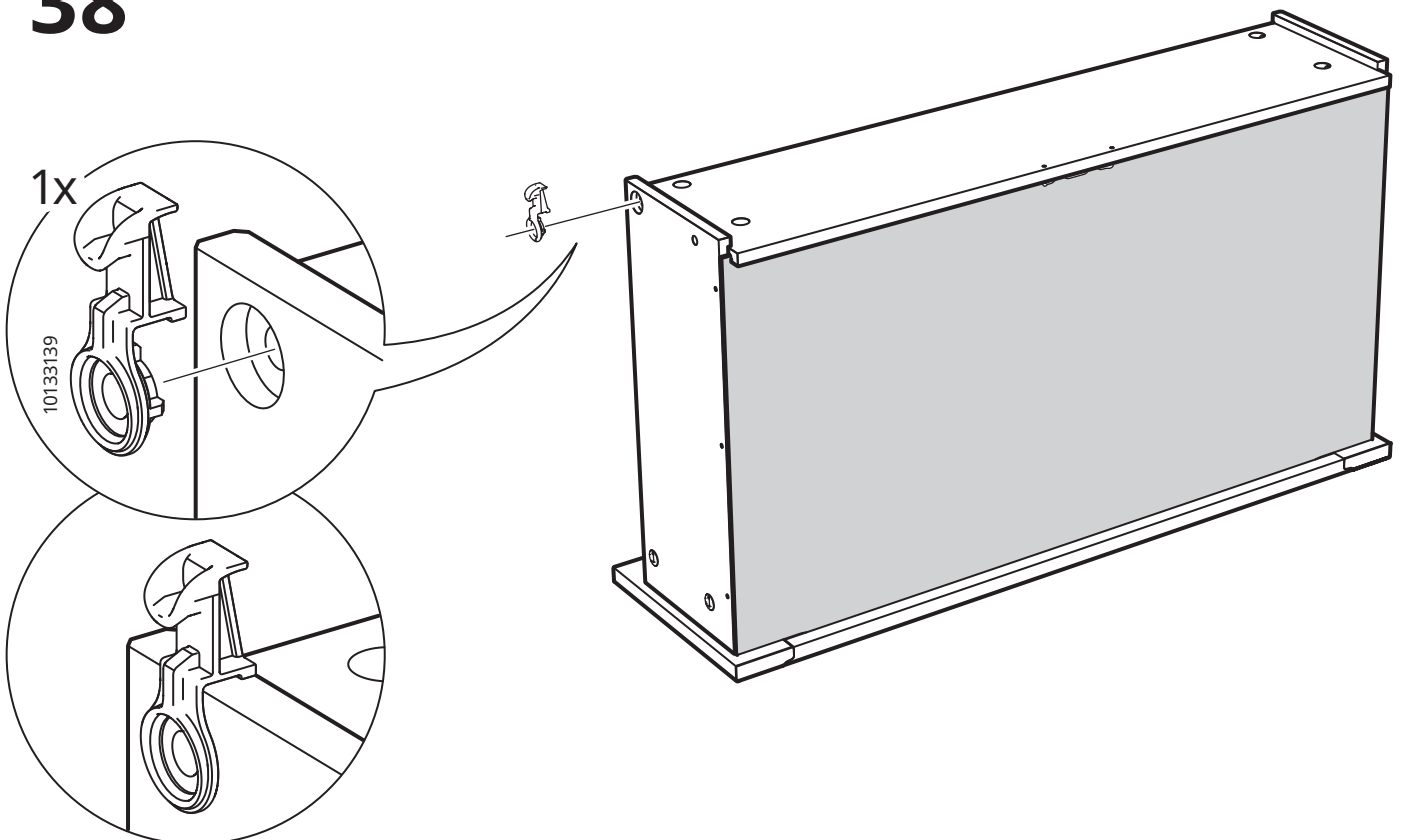

# 39

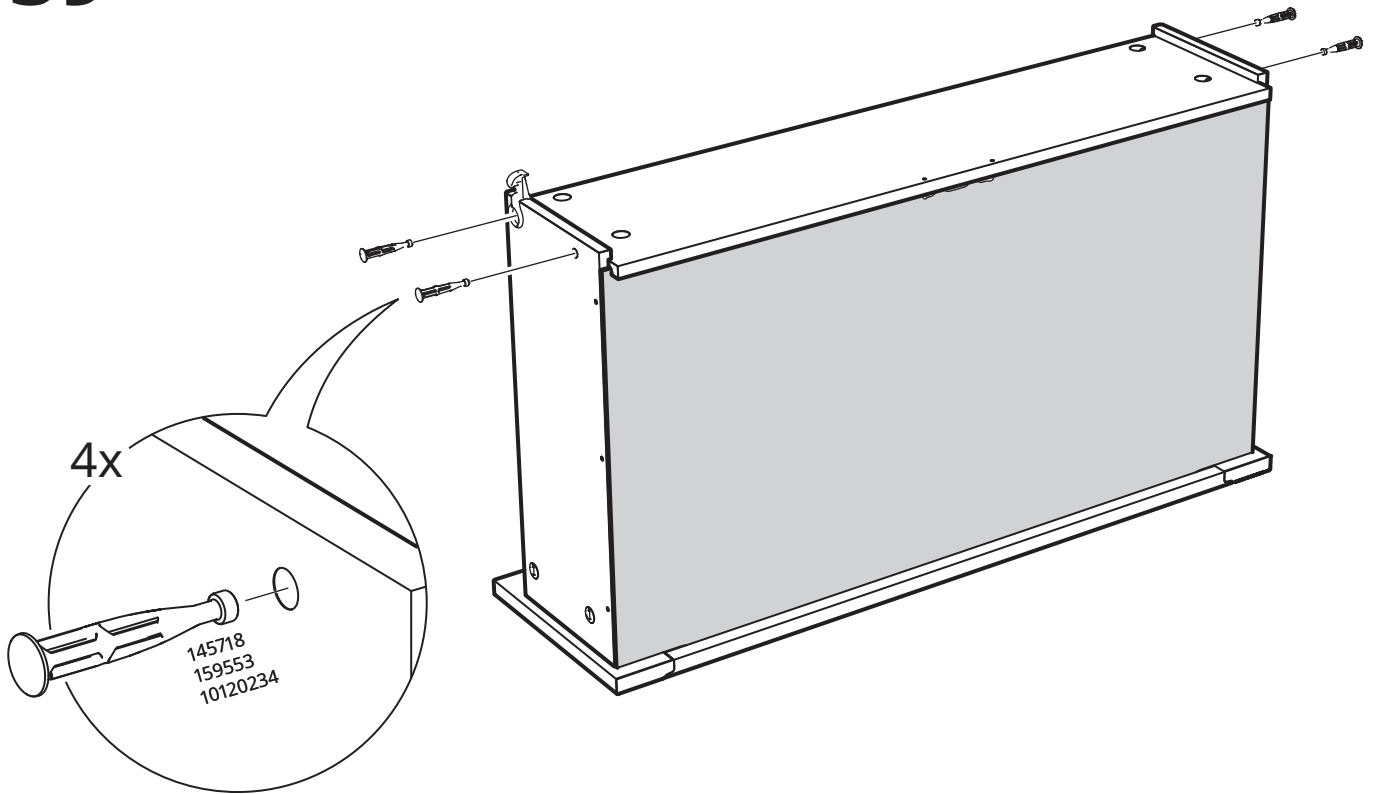

# 40

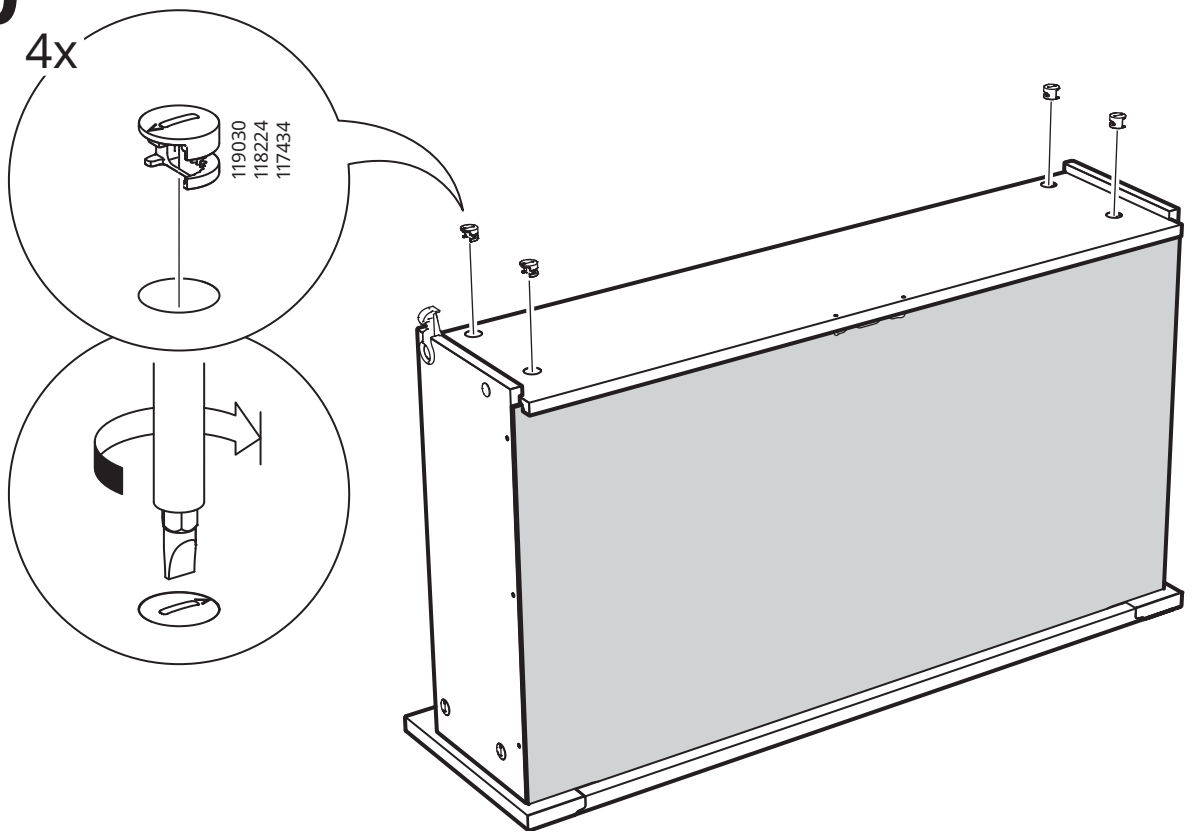

# 41

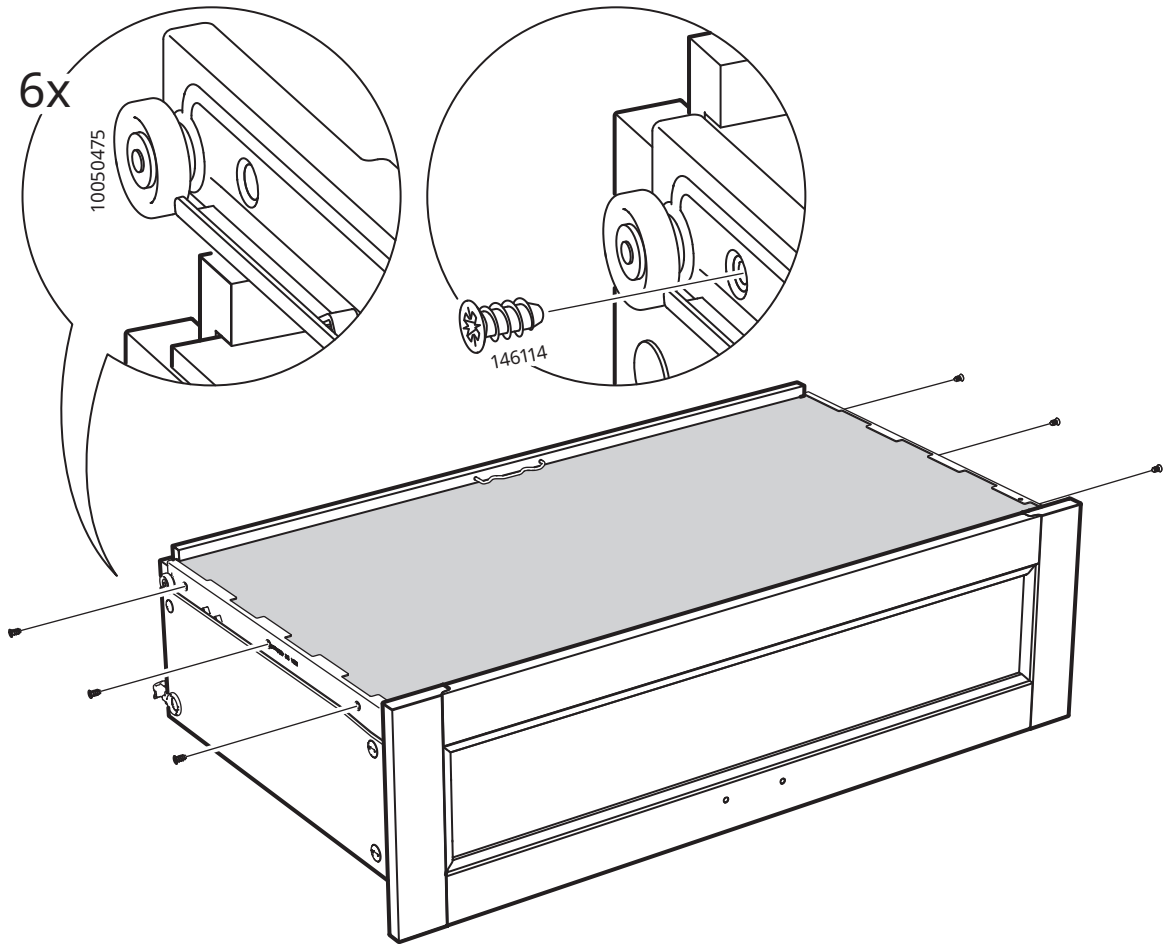

# 42

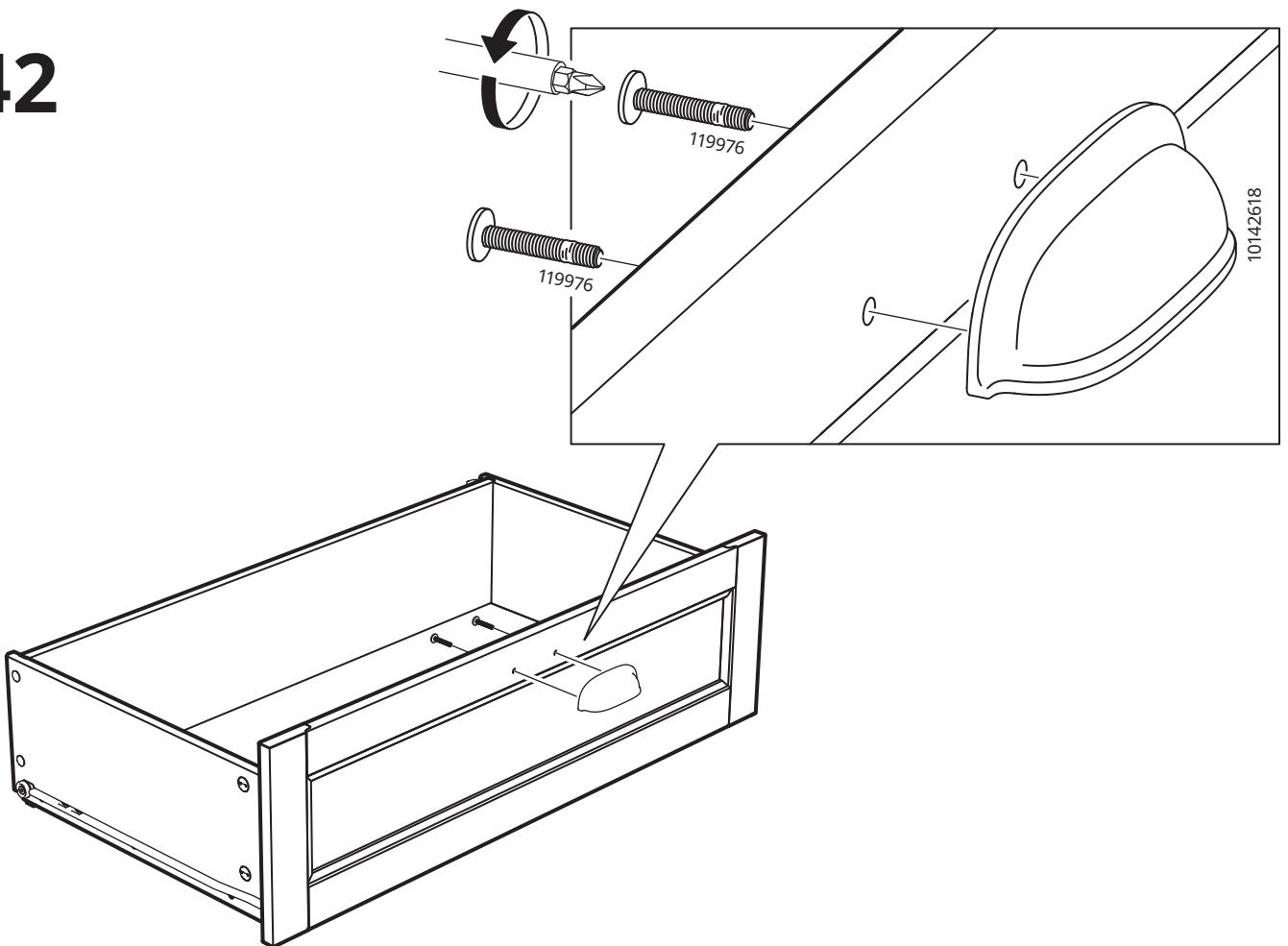

43

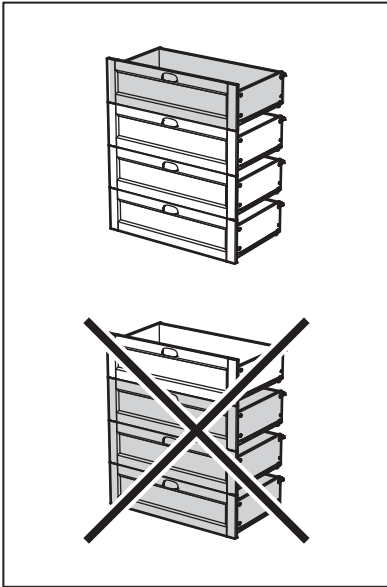
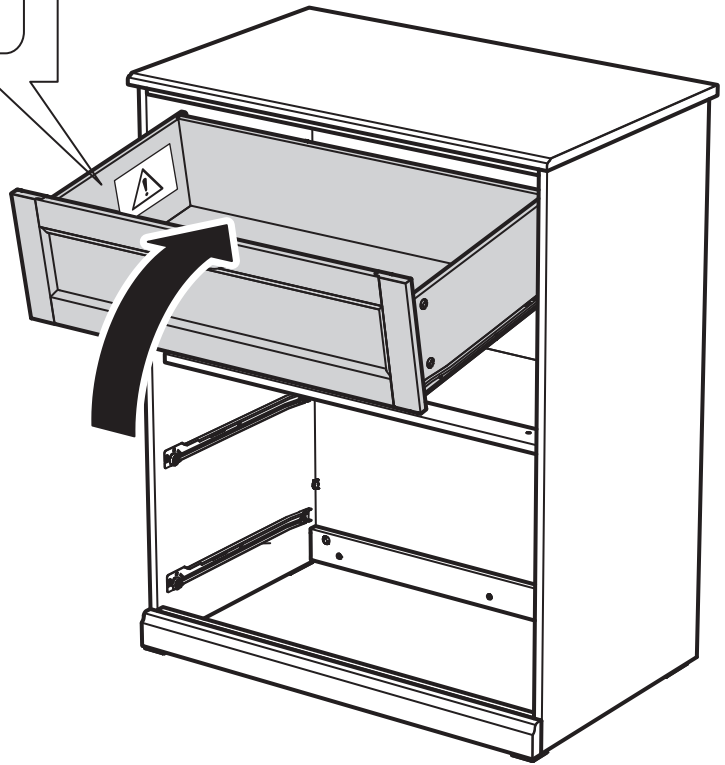

44

